

## 30 V, 2 A Synchronous PWM Step-down DC/DC Converter for Automotive Applications

No. EC-530-201208

### OVERVIEW

The R1278S is a 36 V maximum rated synchronous step-down DC/DC converter with built-in drivers. With the operating frequency at 2 MHz and a spread-spectrum clock generator, the interference effect on the AM band is small. Under cranking condition, the switching frequency is automatically reduced to keep output voltage level constant.

### KEY BENEFITS

- Provides a high switching frequency at 2 MHz with the efficiency of 87%.
- Maintains the output voltage constant at cranking by reducing a switching frequency to the minimum of 1/4.
- Achieves the EMI noise reduction by using a spread spectrum clock generator. (Diffusion Rate: +10%).

### KEY SPECIFICATIONS

- Input Voltage Range (Maximum Ratings): 3.6 V to 30 V (36 V)
- Operating Temperature Range: -40°C to 125°C
- Start-up Voltage: 4.5 V
- Standby Current: Typ. 4  $\mu$ A
- Output Voltage Range: 3.3 V to 5.0 V
- Feedback Voltage: 0.64 V  $\pm$ 1.0%
- Adjustable Oscillator Frequency Using External Resistors: 2 MHz
- External Synchronous Clock Frequency: 1.8 MHz to 2.2 MHz
- Spread Spectrum Clock Generator (SSCG): Diffusion Rate: Typ. +10%
- Minimum ON-Time: Typ. 70 ns
- Minimum OFF-Time: Typ. 120 ns
- Duty-over: Set Frequency (external input frequency) x 1 to 1/4
- Soft-start: (Tracking available with an external voltage application)
- Thermal Shutdown:  $T_j = 160^\circ\text{C}$
- Undervoltage Lockout (UVLO):  $V_{CC} = 3.3$  V (Typ.)
- Overvoltage Lockout (OVLO):  $V_{IN} = 35$  V (Typ.)
- Overvoltage Detection (OVD): FB Pin Voltage ( $V_{FB}$ ) +10%
- LX Current Limiting: Typ. 3 A
- High-side Driver ON Resistance: Typ. 0.145  $\Omega$
- Low-side Driver ON Resistance: Typ. 0.095  $\Omega$

### TYPICAL CHARACTERISTICS

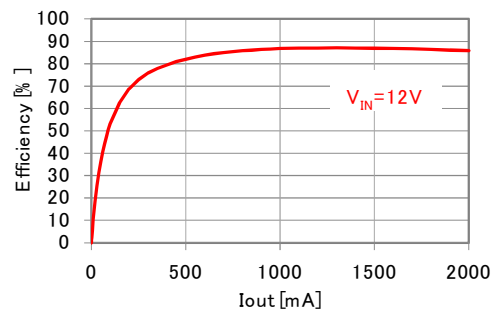

Efficiency ( $V_{out} = 5$  V)

### PACKAGE

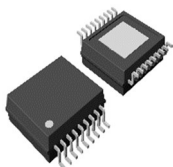

HSOP-18

5.2 x 6.2 x 1.45 (mm)

### OPTIONAL FUNCTIONS

Choose the optional functions from below.

Product Name	SSCG
R1278S003A	Disable
R1278S003C	Enable

### APPLICATIONS

- Voltage monitoring for accessories such as car audios, car navigation systems and ETC system
- Power supply for electronic control units such as EV inverter and battery charge control unit

## SELECTION GUIDE

### Selection Guide

Product Name	Package	Quantity per Reel	Pb Free	Halogen Free
R1278S003*-E2-#E	HSOP-18	1,000 pcs	Yes	Yes

\* : Select the optional functions.

*	Overcurrent Protection	SSCG
A	Hiccup-type	Disable
C	Hiccup-type	Enable

# : Select the quality class.

#	Operating Temperature Range	Test Temp.
A	-40°C to 125°C	25°C, High
K	-40°C to 125°C	Low, 25°C, High

# BLOCK DIAGRAM

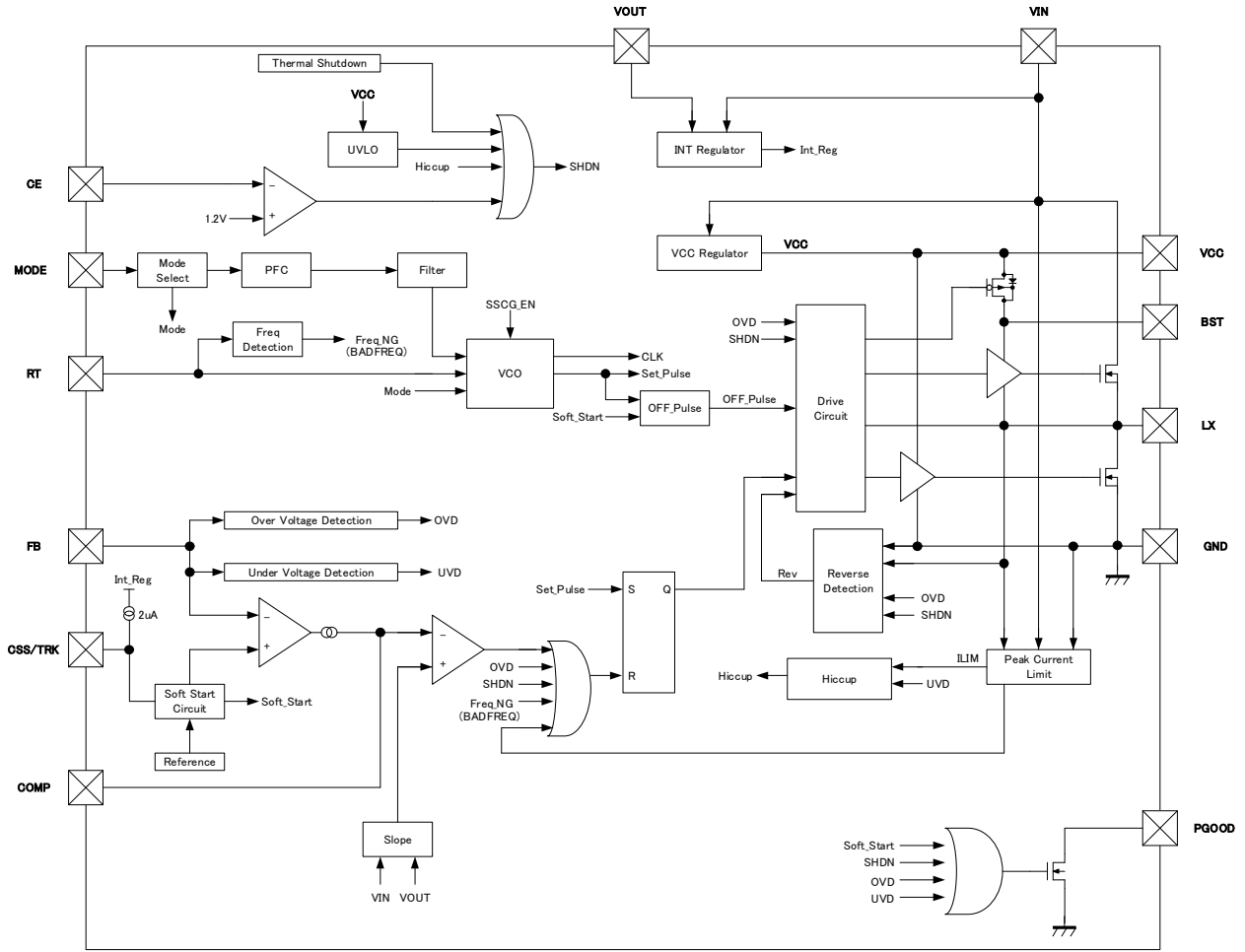

R1278S Block Diagram

## PIN DESCRIPTIONS

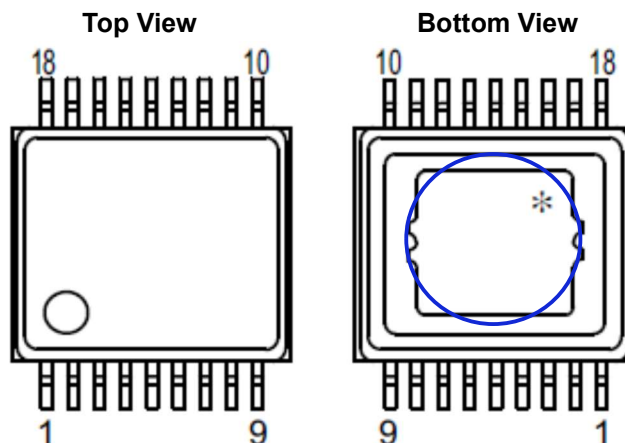

**R1278S (HSOP-18) Pin Configuration**

\* The tab on the bottom of the package is substrate level (GND). The tab must be connected to the ground plane on the board.

### R1278S Pin Descriptions

Pin No.	Pin Name	Description
1, 2	VIN <sup>(1)</sup>	Power Supply Pin
3	NC <sup>(2)</sup>	No Connection
4	CE	Chip Enable Pin, Active-high
5	CSS/TRK	Soft-start Adjustment Pin
6	COMP	Capacitor Connecting Pin for Error Amplifier's Phase Compensation
7	FB	Feedback Input Pin for Error Amplifier
8	PGOOD	Power Good Output Pin
9	VOUT	Output Voltage Feedback Input Pin
10	MODE <sup>(3)</sup>	Mode Setting Input Pin
11	RT	Oscillator Frequency Adjustment Pin
12	VCC	VCC Output Pin
13	BST	Bootstrap Pin
14, 15, 16	GND <sup>(1)</sup>	GND Pin
17	NC <sup>(2)</sup>	No Connection
18	LX	Switching Pin

<sup>(1)</sup> The pins with the same name should be connected together when mounted on a board.

<sup>(2)</sup> NC pin should be set to "Open".

<sup>(3)</sup> MODE pin should be used with High or with external clock input.

Equivalent Circuits for the Individual Terminals

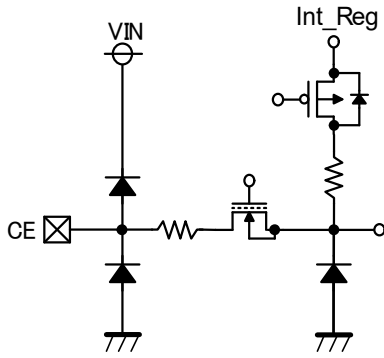

Equivalent Circuit for CE Pin

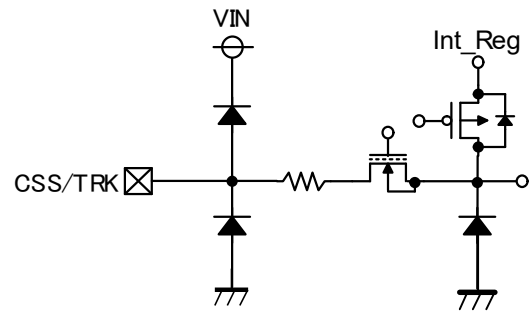

Equivalent Circuit for CSS/TRK Pin

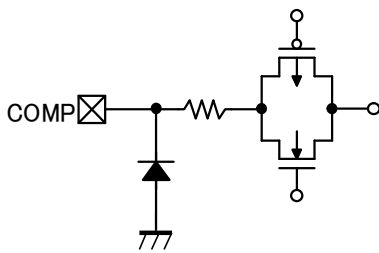

Equivalent Circuit for COMP Pin

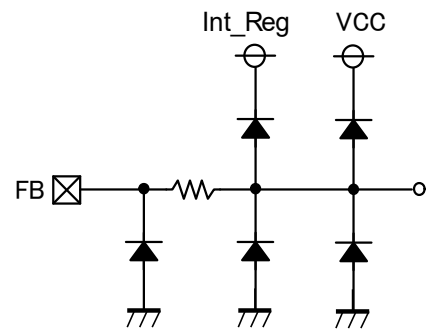

Equivalent Circuit for FB Pin

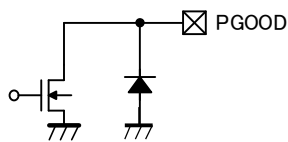

Equivalent Circuit for PGOOD Pin

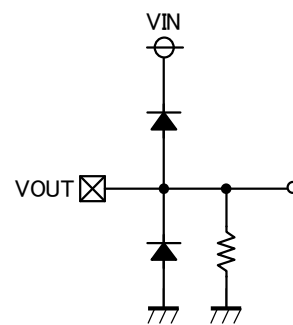

Equivalent Circuit for VOUT Pin

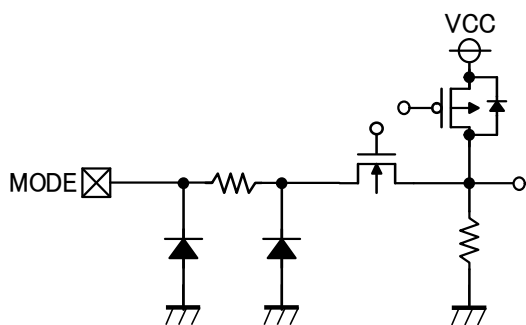

Equivalent Circuit for MODE Pin

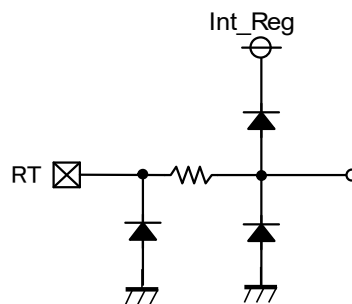

Equivalent Circuit for RT Pin

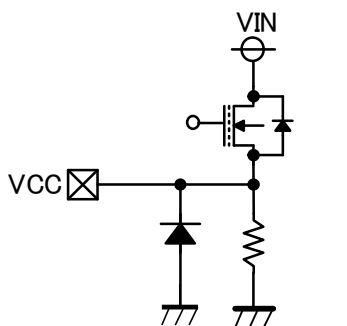

Equivalent Circuit for VCC Pin

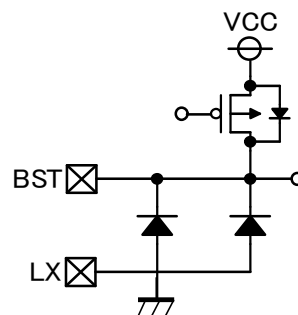

Equivalent Circuit for BST Pin

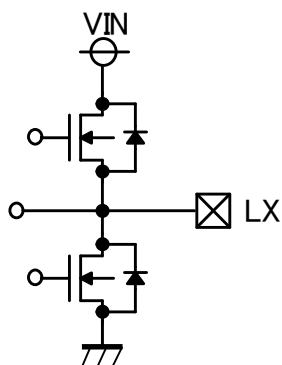

Equivalent Circuit for LX Pin

## ABSOLUTE MAXIMUM RATINGS

### Absolute Maximum Ratings

Symbol	Parameter	Rating	Unit
$V_{IN}$	VIN Pin Input Voltage	-0.3 to 36	V
$V_{CE}$	CE Pin Voltage	-0.3 to $V_{IN} + 0.3 \leq 36$	V
$V_{CSS/TRK}$	CSS/TRK Pin Voltage	-0.3 to 3	V
$V_{OUT}$	VOUT Pin Voltage	-0.3 to 16	V
$V_{RT}$	RT Pin Voltage	-0.3 to 3	V
$V_{COMP}$	COMP Pin Voltage <sup>(1)</sup>	-0.3 to 6	V
$V_{FB}$	FB Pin Voltage	-0.3 to 3	V
$V_{CC}$	VCC Pin Voltage	-0.3 to 6	V
	VCC Pin Output Current	Internally Limited	mA
$V_{BST}$	BST Pin Voltage	LX-0.3 to LX+6	V
$V_{LX}$	LX Pin Voltage	-0.3 to $V_{IN} + 0.3 \leq 36$	V
$V_{MODE}$	MODE Pin Voltage	-0.3 to 6	V
$V_{PGOOD}$	PGOOD Pin Voltage	-0.3 to 6	V
$P_D$	Power Dissipation	Refer to Appendix "Power Dissipation"	
$T_j$	Junction Temperature Range	-40 to 150	°C
$T_{stg}$	Storage Temperature Range	-55 to 150	°C

### ABSOLUTE MAXIMUM RATINGS

Electronic and mechanical stress momentarily exceeded absolute maximum ratings may cause permanent damage and may degrade the lifetime and safety for both device and system using the device in the field. The functional operation at or over these absolute maximum ratings is not assured.

## RECOMMENDED OPERATING CONDITIONS

### Recommended Operating Conditions

Symbol	Parameter	Rating	Unit
$V_{IN}$	Operating Input Voltage	3.6 to 30	V
$T_a$	Operating Temperature Range	-40 to 125	°C

### RECOMMENDED OPERATING CONDITIONS

All of electronic equipment should be designed that the mounted semiconductor devices operate within the recommended operating conditions. The semiconductor devices cannot operate normally over the recommended operating conditions, even if they are used over such conditions by momentary electronic noise or surge. And the semiconductor devices may receive serious damage when they continue to operate over the recommended operating conditions.

<sup>(1)</sup> It should not exceed  $V_{CC} + 0.3$  V.

## ELECTRICAL CHARACTERISTICS

$V_{IN} = 12\text{ V}$ ,  $V_{CE} = V_{IN}$ , unless otherwise specified.

The specifications surrounded by   are guaranteed by design engineering at  $-40^{\circ}\text{C} \leq T_a \leq 125^{\circ}\text{C}$ .

### R1278S-AE Electrical Characteristics

( $T_a = 25^{\circ}\text{C}$ )

Symbol	Parameter	Conditions	Min.	Typ.	Max.	Unit
$V_{START}$	Start-up Voltage				<span style="border: 1px solid black; padding: 0 2px;">4.5</span>	V
$V_{CC}$	VCC Pin Voltage (VCC-GND)	$V_{FB} = 0.672\text{ V}$ , $V_{MODE} = 5\text{ V}$	<span style="border: 1px solid black; padding: 0 2px;">4.75</span>	5	<span style="border: 1px solid black; padding: 0 2px;">5.25</span>	V
$I_{STANDBY}$	Standby Current	$V_{IN} = 30\text{ V}$ , $V_{CE} = 0\text{ V}$		4	<span style="border: 1px solid black; padding: 0 2px;">30</span>	$\mu\text{A}$
$I_{VIN1}$	VIN Consumption Current 1 at PWM switching stop	$V_{FB} = 0.672\text{ V}$ , $V_{MODE} = 5\text{ V}$ , $V_{OUT} = V_{LX} = 5\text{ V}$		1.0	<span style="border: 1px solid black; padding: 0 2px;">1.35</span>	mA
$V_{UVLO1}$	Undervoltage Lockout (UVLO) Threshold	$V_{CC}$ Falling	<span style="border: 1px solid black; padding: 0 2px;">3.1</span>	3.3	<span style="border: 1px solid black; padding: 0 2px;">3.4</span>	V
$V_{UVLO2}$		$V_{CC}$ Rising	<span style="border: 1px solid black; padding: 0 2px;">4.1</span>	4.3	<span style="border: 1px solid black; padding: 0 2px;">4.5</span>	
$V_{OVLO1}$	Overvoltage Lockout (OVLO) Threshold	$V_{IN}$ Rising	<span style="border: 1px solid black; padding: 0 2px;">33.6</span>	35	<span style="border: 1px solid black; padding: 0 2px;">36</span>	V
$V_{OVLO2}$		$V_{IN}$ Falling	<span style="border: 1px solid black; padding: 0 2px;">32</span>	34		
$V_{FB}$	FB Voltage Accuracy	$T_a = 25^{\circ}\text{C}$	0.6336	0.64	0.6464	V
		$-40^{\circ}\text{C} \leq T_a \leq 125^{\circ}\text{C}$	<span style="border: 1px solid black; padding: 0 2px;">0.6272</span>		<span style="border: 1px solid black; padding: 0 2px;">0.6528</span>	
$f_{OSC0}$	Oscillator Frequency 0	$R_{RT} = 14\text{ k}\Omega$	<span style="border: 1px solid black; padding: 0 2px;">1800</span>	2000	<span style="border: 1px solid black; padding: 0 2px;">2200</span>	kHz
$f_{SYNC}$	Synchronizing Frequency		<span style="border: 1px solid black; padding: 0 2px;">1800</span>		<span style="border: 1px solid black; padding: 0 2px;">2200</span>	kHz
$t_{SS1}$	Soft-start Time 1	$C_{SS} = \text{OPEN}$	<span style="border: 1px solid black; padding: 0 2px;">0.36</span>		<span style="border: 1px solid black; padding: 0 2px;">0.75</span>	ms
$t_{SS2}$	Soft-start Time 2	$C_{SS} = 4.7\text{ nF}$	<span style="border: 1px solid black; padding: 0 2px;">1.4</span>		<span style="border: 1px solid black; padding: 0 2px;">2</span>	ms
$I_{TSS}$	CSS/TRK Pin Charging Current	$V_{CSS/TRK} = 0\text{ V}$	<span style="border: 1px solid black; padding: 0 2px;">1.8</span>	2	<span style="border: 1px solid black; padding: 0 2px;">2.2</span>	$\mu\text{A}$
$V_{SSEND}$	CSS/TRK Pin Voltage at Soft-start stop		$V_{FB}$	$V_{FB} + 0.03$	<span style="border: 1px solid black; padding: 0 2px;"><math>V_{FB} + 0.06</math></span>	V
$R_{DIS\_CSS/TRK}$	CSS/TRK Pin Discharge Resistance	$V_{IN} = 4.5\text{ V}$ , $V_{CE} = 0\text{ V}$ , $V_{CSS/TRK} = 3\text{ V}$	<span style="border: 1px solid black; padding: 0 2px;">1.8</span>	3	<span style="border: 1px solid black; padding: 0 2px;">5</span>	k $\Omega$
$I_{LXLIMIT}$	LX Current Limiting	High-side Transistor, DC Current	<span style="border: 1px solid black; padding: 0 2px;">2.55</span>	3.0	<span style="border: 1px solid black; padding: 0 2px;">3.45</span>	A
$I_{REVLIMIT}$	Reverse Current Limiting	Low-side Transistor, DC Current		1.35	<span style="border: 1px solid black; padding: 0 2px;">2.0</span>	A
$V_{CEH}$	CE "High" Input Voltage		<span style="border: 1px solid black; padding: 0 2px;">1.25</span>			V
$V_{CEL}$	CE "Low" Input Voltage				<span style="border: 1px solid black; padding: 0 2px;">1.1</span>	V
$I_{CEH}$	CE "High" Input Current	$V_{IN} = V_{CE} = 30\text{ V}$		1.2	<span style="border: 1px solid black; padding: 0 2px;">2.45</span>	$\mu\text{A}$
$I_{CEL}$	CE "Low" Input Current	CE "Low"	<span style="border: 1px solid black; padding: 0 2px;">-0.1</span>	0	<span style="border: 1px solid black; padding: 0 2px;">0.1</span>	$\mu\text{A}$
$I_{FBH}$	FB "High" Input Current	$V_{FB} = 0.672\text{ V}$	<span style="border: 1px solid black; padding: 0 2px;">-0.1</span>	0	<span style="border: 1px solid black; padding: 0 2px;">0.1</span>	$\mu\text{A}$
$I_{FBL}$	FB "Low" Input Current	$V_{FB} = 0\text{ V}$	<span style="border: 1px solid black; padding: 0 2px;">-0.1</span>	0	<span style="border: 1px solid black; padding: 0 2px;">0.1</span>	$\mu\text{A}$

All test items listed in Electrical Characteristics are done under the pulse load condition ( $T_j \approx T_a = 25^{\circ}\text{C}$ ).



$V_{IN} = 12\text{ V}$ ,  $V_{CE} = V_{IN}$ , unless otherwise specified.

The specifications surrounded by   are guaranteed by design engineering at  $-40^{\circ}\text{C} \leq T_a \leq 125^{\circ}\text{C}$ .

**R1278S-AE Electrical Characteristics (Continued)**
**( $T_a = 25^{\circ}\text{C}$ )**

Symbol	Parameter	Conditions	Min.	Typ.	Max.	Unit
$V_{MODEH}$	MODE "High" Input Voltage		<span style="border: 1px solid black; padding: 0 2px;">1.40</span>			V
$I_{MODEH}$	MODE "High" Input Current	$V_{MODE} = 5\text{ V}$		6.25	<span style="border: 1px solid black; padding: 0 2px;">14.0</span>	$\mu\text{A}$
$V_{PGOODOFF}$	PGOOD "Low" Output Voltage	$V_{IN} = 3.6\text{ V}$ , $I_{PGOOD} = 1\text{ mA}$			<span style="border: 1px solid black; padding: 0 2px;">0.25</span>	V
$I_{PGOODOFF}$	PGOOD Pin Leakage Current	$V_{IN} = 30\text{ V}$ , $V_{PGOOD} = 6\text{ V}$			<span style="border: 1px solid black; padding: 0 2px;">100</span>	nA
$V_{FBOVD1}$	FB Pin Overvoltage Detection (OVD) Threshold	$V_{FB}$ Rising	$V_{FB}$ <span style="border: 1px solid black; padding: 0 2px;">x1.060</span>	$V_{FB}$ x1.10	$V_{FB}$ <span style="border: 1px solid black; padding: 0 2px;">x1.140</span>	V
$V_{FBOVD2}$		$V_{FB}$ Falling	$V_{FB}$ <span style="border: 1px solid black; padding: 0 2px;">x1.024</span>	$V_{FB}$ X 1.07	$V_{FB}$ <span style="border: 1px solid black; padding: 0 2px;">x1.111</span>	V
$V_{FBUVD1}$	FB Pin Undervoltage Detection (UVD) Threshold	$V_{FB}$ Falling	$V_{FB}$ <span style="border: 1px solid black; padding: 0 2px;">x0.860</span>	$V_{FB}$ X 0.90	$V_{FB}$ <span style="border: 1px solid black; padding: 0 2px;">x0.946</span>	V
$V_{FBUVD2}$		$V_{FB}$ Rising	$V_{FB}$ <span style="border: 1px solid black; padding: 0 2px;">x0.895</span>	$V_{FB}$ X 0.93	$V_{FB}$ <span style="border: 1px solid black; padding: 0 2px;">x0.974</span>	V

All test items listed in Electrical Characteristics are done under the pulse load condition ( $T_j \approx T_a = 25^{\circ}\text{C}$ ).

$V_{IN} = 12\text{ V}$ ,  $V_{CE} = V_{IN}$ , unless otherwise specified.

## R1278S-KE Electrical Characteristics

(-40°C ≤ Ta ≤ 125°C)

Symbol	Parameter	Conditions	Min.	Typ.	Max.	Unit
$V_{START}$	Start-up Voltage				4.5	V
$V_{CC}$	VCC Pin Voltage (VCC-GND)	$V_{FB} = 0.672\text{ V}$ , $V_{MODE} = 5\text{ V}$	4.75	5	5.25	V
$I_{STANDBY}$	Standby Current	$V_{IN} = 30\text{ V}$ , $V_{CE} = 0\text{ V}$		4	30	μA
$I_{VIN1}$	VIN Consumption Current 1 at PWM switching stop	$V_{FB} = 0.672\text{ V}$ , $V_{MODE} = 5\text{ V}$ , $V_{OUT} = V_{LX} = 5\text{ V}$		1.0	1.35	mA
$V_{UVLO1}$	Undervoltage Lockout (UVLO) Threshold	$V_{CC}$ Falling	3.1	3.3	3.4	V
$V_{UVLO2}$		$V_{CC}$ Rising	4.1	4.3	4.5	
$V_{OVLO1}$	Undervoltage Lockout (OVLO) Threshold	$V_{IN}$ Rising	33.6	35	36	V
$V_{OVLO2}$		$V_{IN}$ Falling	32	34		
$V_{FB}$	FB Voltage Accuracy	Ta = 25°C	0.6336	0.64	0.6464	V
		-40°C ≤ Ta ≤ 125°C	0.6272		0.6528	
$f_{OSC0}$	Oscillator Frequency 0	$R_{RT} = 14\text{ k}\Omega$	1800	2000	2200	kHz
$f_{SYNC}$	Synchronizing Frequency		1800		2200	kHz
$t_{SS1}$	Soft-start Time 1	$C_{SS} = \text{OPEN}$	0.36		0.75	ms
$t_{SS2}$	Soft-start Time 2	$C_{SS} = 4.7\text{ nF}$	1.4		2	ms
$I_{TSS}$	CSS/TRK Pin Charging Current	$V_{CSS/TRK} = 0\text{ V}$	1.8	2	2.2	μA
$V_{SSEND}$	CSS/TRK Pin Voltage at Soft-start stop		$V_{FB}$	$V_{FB} + 0.03$	$V_{FB} + 0.06$	V
$R_{DIS\_CSS/TRK}$	CSS/TRK Pin Discharge Resistance	$V_{IN} = 4.5\text{ V}$ , $V_{CE} = 0\text{ V}$ , $V_{CSS/TRK} = 3\text{ V}$	1.8	3	5	kΩ
$I_{LXLIMIT}$	LX Current Limiting	High-side Transistor, DC Current	2.55	3.0	3.45	A
$I_{REVLIMIT}$	Reverse Current Limiting	Low-side Transistor, DC Current		1.35	2.0	A
$V_{CEH}$	CE "High" Input Voltage		1.25			V
$V_{CEL}$	CE "Low" Input Voltage				1.1	V
$I_{CEH}$	CE "High" Input Current	$V_{IN} = V_{CE} = 30\text{ V}$		1.2	2.45	μA
$I_{CEL}$	CE "Low" Input Current	CE "Low"	-0.1	0	0.1	μA
$I_{FBH}$	FB "High" Input Current	$V_{FB} = 0.672\text{ V}$	-0.1	0	0.1	μA
$I_{FBL}$	FB "Low" Input Current	$V_{FB} = 0\text{ V}$	-0.1	0	0.1	μA

All test items listed in Electrical Characteristics are done under the pulse load condition ( $T_j \approx T_a = 25^\circ\text{C}$ ).

$V_{IN} = 12\text{ V}$ ,  $V_{CE} = V_{IN}$ , unless otherwise specified.

**R1278S-KE Electrical Characteristics (Continued)****( $-40^{\circ}\text{C} \leq T_a \leq 125^{\circ}\text{C}$ )**

Symbol	Parameter	Conditions	Min.	Typ.	Max.	Unit
$V_{MODEH}$	MODE "High" Input Voltage		1.40			V
$I_{MODEH}$	MODE "High" Input Current	$V_{MODE} = 5\text{ V}$		6.25	14.0	$\mu\text{A}$
$V_{PGOODOFF}$	PGOOD "Low" Output Voltage	$V_{IN} = 3.6\text{ V}$ , $I_{PGOOD} = 1\text{ mA}$			0.25	V
$I_{PGOODOFF}$	PGOOD Pin Leakage Current	$V_{IN} = 30\text{ V}$ , $V_{PGOOD} = 6\text{ V}$			100	nA
$V_{FBOVD1}$	FB Pin Overvoltage Detection (OVD) Threshold	$V_{FB}$ Rising	$V_{FB}$ x1.060	$V_{FB}$ x1.10	$V_{FB}$ x1.140	V
$V_{FBOVD2}$		$V_{FB}$ Falling	$V_{FB}$ x1.024	$V_{FB}$ X 1.07	$V_{FB}$ x1.111	V
$V_{FBUVD1}$	FB Pin Undervoltage Detection (UVD) Threshold	$V_{FB}$ Falling	$V_{FB}$ x0.860	$V_{FB}$ X 0.90	$V_{FB}$ x0.946	V
$V_{FBUVD2}$		$V_{FB}$ Rising	$V_{FB}$ x0.895	$V_{FB}$ X 0.93	$V_{FB}$ x0.974	V

All test items listed in Electrical Characteristics are done under the pulse load condition ( $T_j \approx T_a = 25^{\circ}\text{C}$ ).

## TYPICAL APPLICATION CIRCUIT

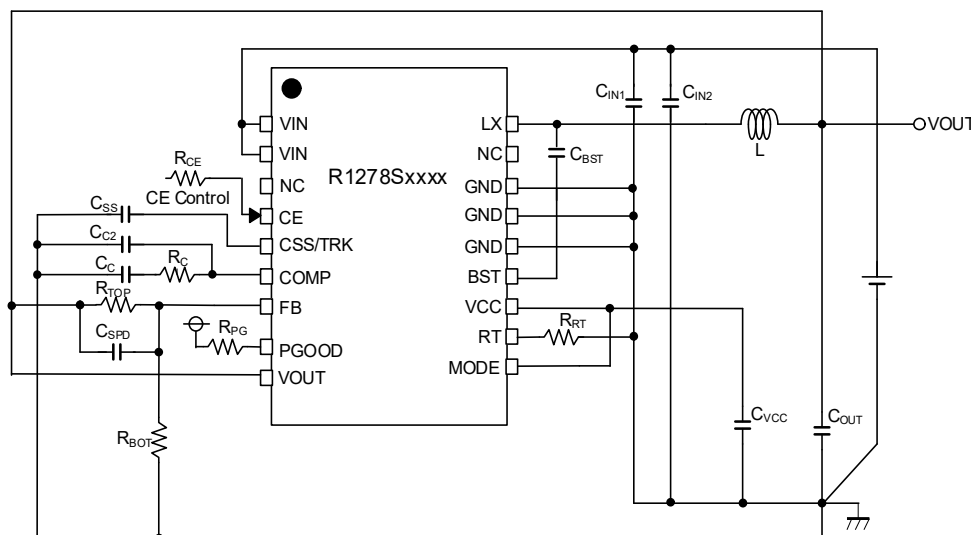

R1278S Typical Application Circuit

## Recommended Values

V <sub>OUT</sub>	C <sub>IN</sub> [μF]	L [μH]	C <sub>OUT</sub> [μF]	C <sub>BST</sub> [μF]	C <sub>VCC</sub> [μF]	C <sub>SPD</sub> <sup>(1)</sup> [pF]	R <sub>TOP</sub> [kΩ]	R <sub>BOT</sub> [kΩ]	R <sub>RT</sub> [kΩ]	R <sub>C</sub> [kΩ]	C <sub>C</sub> [nF]	C <sub>C2</sub> [pF]
3.3 V	21 (10×2+1)	2.2	48.7 (22×2+4.7)	0.1	1.0	10	162 (150+12)	39	14	8.2	4.7	-
5.0 V	21 (10×2+1)	2.2	48.7 (22×2+4.7)	0.1	1.0	10	267 (220+47)	39	14	12	4.7	-

It is recommended to set 1 kΩ or higher for R<sub>CE</sub>, and between 10 kΩ and 100 kΩ for R<sub>PG</sub>.

## Recommended Parts

Symbol	Capacitance	Tolerance	Voltage resistance	Temperature characteristics
C <sub>IN1, 2</sub>	1.0 μF	±10%	50 V	X7R
	10 μF	±10%	50 V	X7S
C <sub>OUT</sub>	4.7 μF	±10%	25 V	X7R
	22 μF	±20%	16 V	X7R
C <sub>BST</sub>	0.1 μF	±10%	25 V	X7R
C <sub>VCC</sub>	1.0 μF	±10%	16 V	X7R

Symbol	Inductance	Tolerance	Rated current
L	2.2 μH	±30%	5.5 A

<sup>(1)</sup> When changing R<sub>BOT</sub> from the recommended value, change C<sub>SPD</sub> accordingly so that R<sub>BOT</sub> × C<sub>SPD</sub> does not change from the recommended constant. Then the frequency characteristics become the same as the recommended value. For example, in case R<sub>BOT</sub> is multiplied by 1/10, C<sub>SPD</sub> is multiplied by 10 so that the frequency characteristic of the feedback resistor does not change.

## Precautions for Selecting External Components

### Inductor

- Choose an inductor with small DC resistance, sufficient allowable current and hardly causing magnetic saturation. DC resistance affects efficiency. If the inductance value is extremely small, the peak current of LX may increase along with the load current. As a result, the current limit circuit may start to operate before reaching the intended load current.

### Capacitor

- Choose a capacitor with DC bias characteristics and temperature characteristics equal or better than the measurement component of typical characteristics described in the datasheet, and with a sufficient margin to the drive voltage ratings.
- Ceramic capacitors are recommended for the input capacitor ( $C_{IN}$ ) and the output capacitor ( $C_{OUT}$ ). The combined use of a ceramic capacitor and an electrolyte capacitor is recommended. Especially, choose the electrolyte capacitor with the lowest possible ESR with consideration of the allowable ripple current rating ( $I_{RMS}$ ).  $I_{RMS}$  can be calculated by the following equation.

$$I_{RMS} \doteq I_{OUT} / V_{IN} \times \sqrt{V_{OUT} \times (V_{IN} - V_{OUT})}$$

The electrolyte capacitor has a characteristic of increasing ESR when it is at a low temperature, so careful consideration is required on the phase characteristics in case of using an electrolyte capacitor for  $C_{OUT}$ .

## THEORY OF OPERATION

### MODE Pin Function

The R1278S switches the operation mode to either a forced PWM mode or a PLL PWM mode by applying a voltage or a pulse to the MODE pin. By applying 1.4 V or more to the MODE pin, the operation mode goes into the forced PWM mode and operates at forced PWM regardless of a load current. See *Forced PWM Mode* for more details. See *Frequency Synchronization* for the operation when an external clock is connected.

### Frequency Synchronization

The R1278S can switch at the frequency synchronized with the external clock frequency input to the MODE pin by using PLL (Phase Lock Loop). The synchronizable frequency range is between 1.8 MHz to 2.2 MHz. During the synchronization, the operation mode is a forced PWM. The recommended pulse width of the external clock is 100 ns or more. When starting up the device while the external clock is sent to the MODE pin, the device synchronizes to the external clock while starting up with soft-start. Be aware that if the voltage difference between input and output is reduced and the device goes into the maxduty or duty-over condition, the device starts operating at 1/4 of the synchronous frequency and goes into the asynchronous condition with the MODE pin.

### Duty-over

When the input voltage is dropped under the condition such as cranking, the R1278S linearly changes the operating frequency to 1/4 of the set oscillator frequency in order to maintain the output voltage. This can make the on duty more than the normal maxduty and it can also reduce the voltage difference between input and output. The duty-over starts operating when it detects the minimum off-time in the set oscillator frequency and the external synchronous oscillator frequency.

### UVLO (Undervoltage Lockout)

If the VCC pin voltage drops below the UVLO detection threshold of 3.3 V (Typ.) due to the input voltage drop, the R1278S turns the switching off to prevent the malfunction of the device. Due to the switching stop, the output voltage drops according to the load and  $C_{OUT}$ . If the VCC pin voltage rises above the UVLO threshold of 4.3 V (Typ.), the device restarts the operation with soft-start. For the R1278S, 4.5 V, the maximum UVLO release voltage, is a start-up voltage.

### OVLO (Overvoltage Lockout)

If the input voltage rises above the OVLO detection threshold of 35 V (Typ.), the R1278S turns the switching off to prevent malfunctions of the device or damage on the transistor due to overvoltage. Due to the switching stop, the output voltage drops according to the load and  $C_{OUT}$ . If the input voltage drops below the OVLO release threshold of 34 V (Typ.), the device restarts the operation with soft-start. Note that this function does not guarantee the operation exceeding the absolute maximum ratings.

**PGOOD (Power Good) Function**

The power good function with using a NMOS open drain output pin can detect the following states of the R1278S. The NMOS turns on and the PGOOD pin becomes “Low” when detecting them. After the device returns to its original state, the NMOS turns off and the PGOOD pin outputs “High” (PGOOD Input Voltage:  $V_{UP}$ ).

- CE = “Low” (Shut down)
- UVLO
- OVLO
- Thermal Shutdown
- Soft-start
- UVD
- OVD
- Hiccup-type Protection

The PGOOD pin is designed to become 0.25 V or less in “Low” level when the current floating to the PGOOD pin is 1 mA. The use of the PGOOD input voltage ( $V_{UP}$ ) of 5.5 V or less and the pull-up resistor ( $R_{PG}$ ) of 10 k $\Omega$  to 100 k $\Omega$  are recommended. If not using the PGOOD pin, connect it to “Open” or “GND”.

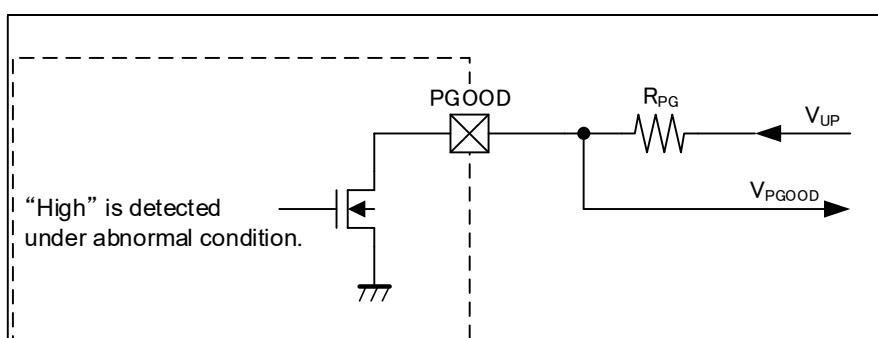
**Power Good Circuit**

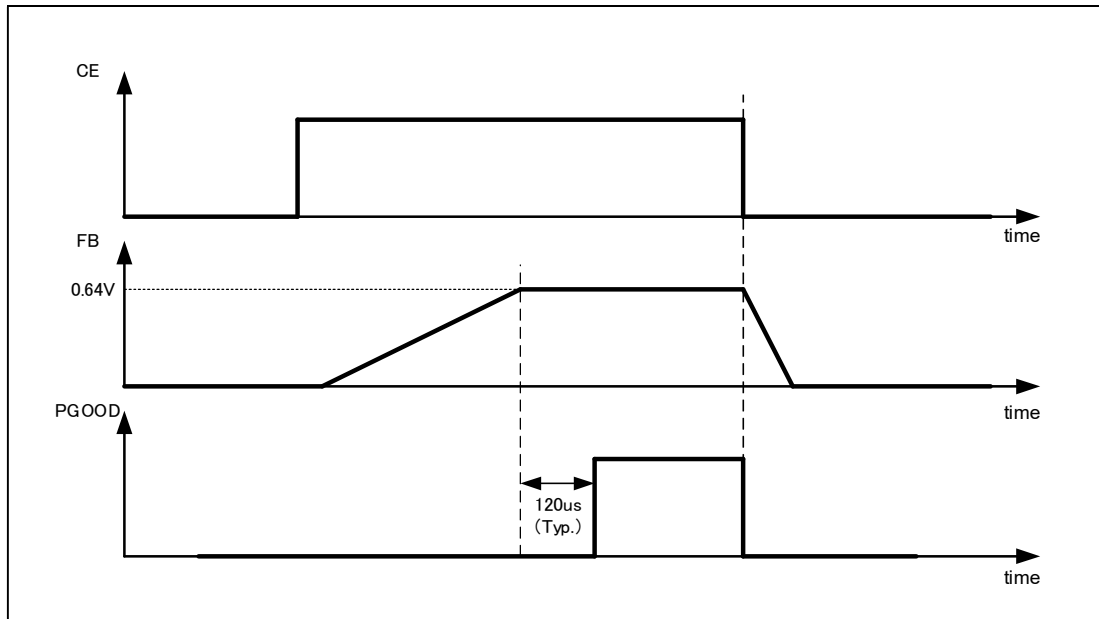

Rising / Falling Sequence of Power Good Circuit



**Under Voltage Detection (UVD)**

The UVD function indirectly monitors the output voltage with using the FB pin. The PGOOD pin outputs “Low” when the UVD detector threshold is 90% (Typ.) of  $V_{FB}$  and  $V_{FB}$  is less than the UVD detector threshold for more than 15  $\mu$ s (Typ.). When  $V_{FB}$  is over 93% (Typ.) of 0.64 V, the PGOOD pin outputs “High” after delay time (Typ. 120  $\mu$ s). And, the hiccup-type overcurrent protection works when detecting a current limiting during the UVD detection.

**Overvoltage Detection (OVD)**

The OVD function indirectly monitors the output voltage with using the FB pin. Switching stops even if the internal circuit is active state, when detecting the overvoltage of  $V_{FB}$ . The PGOOD pin outputs “Low” when the OVD detector threshold is 110% (Typ.) of  $V_{FB}$  and  $V_{FB}$  is over the OVD detector threshold for more than 15  $\mu$ s (Typ.). When  $V_{FB}$  is under 107% (Typ.) of 0.64 V, which is the OVD released voltage, the PGOOD pin outputs “High” after delay time (Typ. 120  $\mu$ s). Then, switching is controlled by normal operation.

**Hiccup-type Overcurrent Protection**

The hiccup-type overcurrent protection can work under the operating conditions that is the UVD can function during the current limiting. The hiccup type protection stops switching and releases the circuit after the protection delay time (Typ. 7.5 ms). Since this protection is auto-release, the CE pin switching of “Low”/“High” is unnecessary. When the output is shorted to GND, switching of “ON” / “OFF” is repeated until the shorting is released.

**Minimum ON-Time**

The minimum on-time means the minimum time duration that the R1278S can turn the high-side transistor on during the oscillation period. The minimum on-time of the device (Typ. 70 ns) is determined by the internal circuit. The device cannot generate a pulse width that is less than the pulse width of minimum on-time. Therefore, when setting the output voltage and the oscillator frequency, be careful that the minimum step-down ratio [ $V_{OUT} / V_{IN} \times (1 / f_{OSC})$ ] is not less than the minimum on-time. If they are set to less than the minimum step-down ratio, the pulse skipping occurs, which outputs the  $V_{OUT}$  but increases the output ripples of current and voltage.

**Minimum OFF-Time**

The minimum OFF-time means the minimum time duration that the R1278S can turn the high-side transistor off during the oscillation period. By the adoption of bootstrap method, the high-side transistor, which is used as the R1278S internal circuit for the minimum off-time, is used a NMOS. The voltage sufficient to drive the high-side transistor must be charged. Therefore, the minimum off-time is determined from the required time to charge the voltage. By the adoption of the frequency’s reduction method by one-quarter of a set value (Min.), if the input-output difference voltage becomes small or load transients are caused, the OFF period can be caused once in four-cycle period of normal cycle. As a result, the minimum off-time becomes 120 ns (Typ.) and the maximum duty cycle can be improved substantially.

**Current Limit**

The output current of the R1278S is limited by the current limit using a peak current method. The current limit is set to 3.0 A (Typ. DC value) and it is fixed inside the IC. The current limit circuit limits the current by monitoring the drain and source voltage of a high-side transistor. The transitional current limit of the inductor current is set to be higher than the DC value. The current limit of the device starts operating after the minimum on-time, so it has to be careful especially when the device is used close to the minimum on-time because the current limit will increase. The following diagram shows the relation between current limit and on-time using Ricoh's evaluation board. The longer the on-time is, the more the current approaches the current limit value of 3.0 A (Typ. DC value).

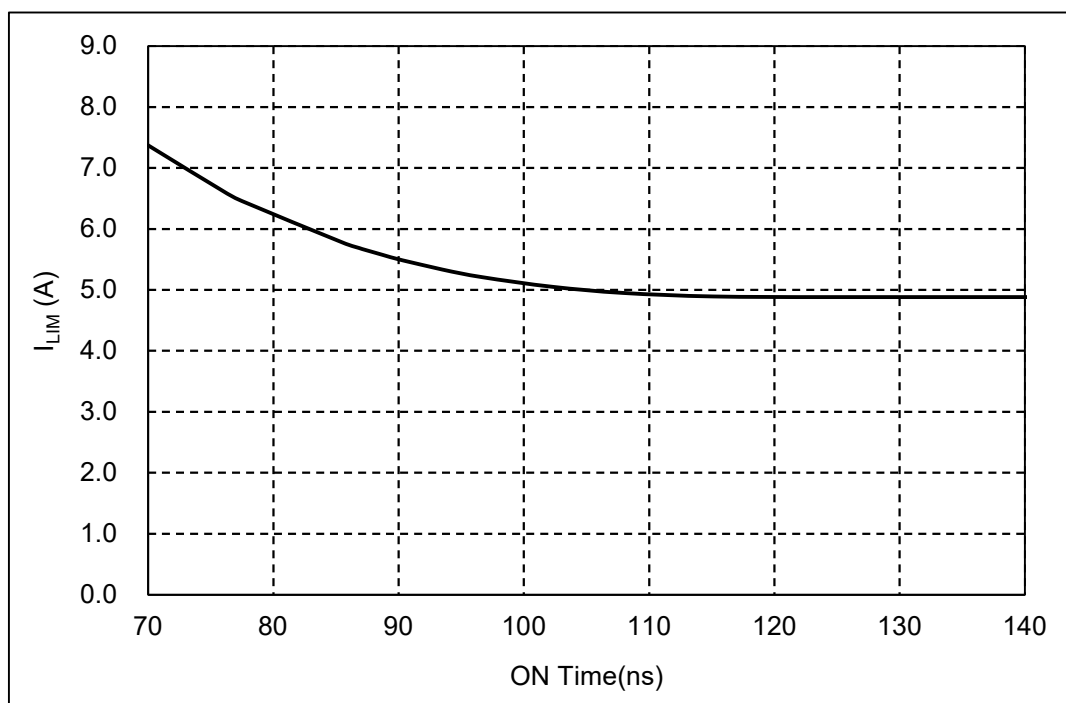
**R1278S Current Limit vs LX ON Time**

### Precautions for Operating in Low Input Voltage

When using the R1278S with  $V_{IN} = 5\text{ V}$  or less, the load current may be limited in following two cases.

First Case: The device designed to reach current limit by monitoring the voltage difference between  $V_{IN}$  and LX. During the low input voltage operation, the driving capability of high-side transistor decreases, so the voltage difference between  $V_{IN}$  and LX becomes larger with smaller output current. Therefore, the load current may be limited during the low input voltage operation.

Second Case: During the low input voltage operation, the duty-over function decreases the oscillator frequency. While the oscillator frequency is 1/4 of the set frequency, drawing the load current can cause a voltage difference between the input and output. These make the device to exit from duty-over condition, and as a result, the output voltage drops.

Both cases show that the current limit is depending on the input voltage and load current. Careful consideration is required when applying a heavy load while the input voltage is low. The following graph shows the relation between input voltage and load current.

If the BST voltage between BST and LX drops extremely, the device forcibly turns off the switching to charge the BST voltage. This may occur when  $V_{IN}$  is 4.5 V or less and it may affect the output voltage ripple. Also, if  $V_{IN}$  is less than 4.5 V and UVD is detected as the output voltage decreases, the hiccup-type overcurrent protection may work due to the protection function inside the IC.

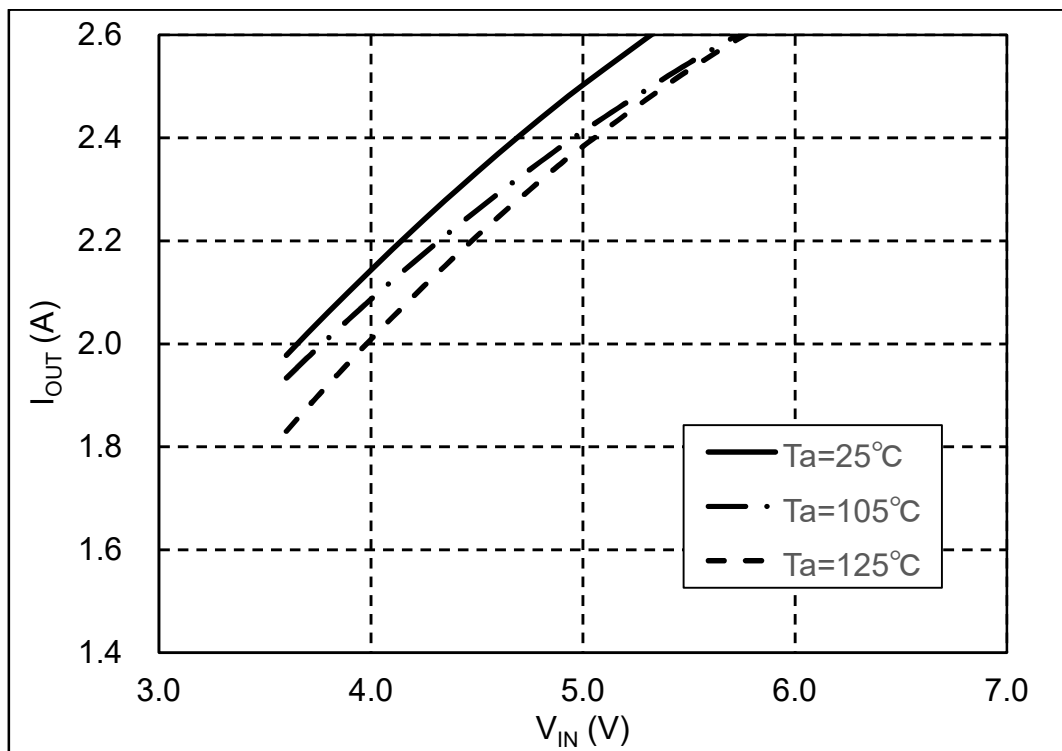

$V_{OUT} = 3.3\text{ V}$  Setting

R1278S Output Current vs Input Voltage

**Output Voltage Setting**

The output voltage ( $V_{OUT}$ ) can be set by adjustable values of  $R_{TOP}$  and  $R_{BOT}$ . The value of  $V_{OUT}$  can be calculated by Equation 1:

$$V_{OUT} = V_{FB} \times (R_{TOP} + R_{BOT}) / R_{BOT} \dots\dots\dots \text{Equation 1}$$

For example, when setting  $V_{OUT} = 3.3 \text{ V}$  and setting  $R_{BOT} = 39 \text{ k}\Omega$ ,  $R_{TOP}$  can be calculated by substituting them to Equation 1. As a result of the expanding Equation 2,  $R_{TOP}$  can be set to 162  $\text{k}\Omega$ .

To make 162  $\text{k}\Omega$  with using the E24 type resistors, the connecting use of 160  $\text{k}\Omega$  and 2  $\text{k}\Omega$  resistors in series is required. If the tolerance level of the set output voltage is wide, using a resistor of 160  $\text{k}\Omega$  to  $R_{TOP}$  can reduce the number of components.  $R_{BOT}$  is recommended to be 39 $\text{k}\Omega$  or less.

$$\begin{aligned} R_{TOP} &= (3.3 \text{ V} / 0.64 \text{ V} - 1) \times 39 \text{ k}\Omega \\ &= 162 \text{ k}\Omega \dots\dots\dots \text{Equation 2} \end{aligned}$$

R1278S is designed assuming  $R_{TOP}$  and  $R_{BOT}$  resistance variation of  $\pm 1\%$ .

**Oscillator Frequency Setting**

Connecting a 14- $\text{k}\Omega$  (Typ.) oscillation frequency setting resistor ( $R_{RT}$ ) between the RT pin and GND can control the oscillation frequency to 2 MHz. The following equation can calculate the variation in resistance of oscillator frequencies. To reduce the variation of oscillator frequencies, it is recommended that a  $\pm 1\%$  or less  $R_{RT}$  be used. For the SSCG type (R1278S003C), an up-spreading modulation is used (Typ. +10%).

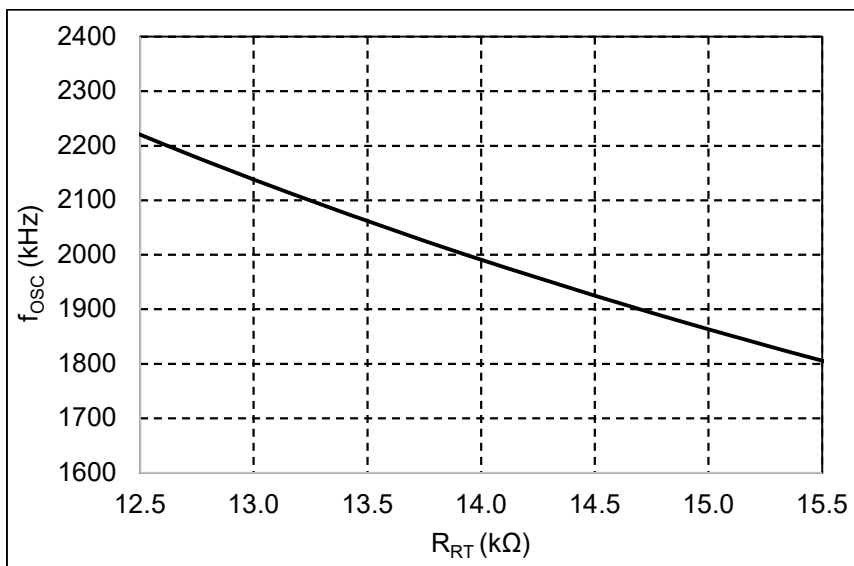

$$R_{RT} [\text{k}\Omega] = 37773 \times f_{osc} [\text{kHz}] ^{-1.04}$$

**R1278S Oscillator Frequency vs Oscillator Frequency Setting Resistance**

**Soft-start Adjustment**

The soft-start time is a time between a rising edge (“High” level) of the CE pin and the timing when the output voltage reaches the set output voltage. Connecting a capacitor ( $C_{SS}$ ) to the CSS/TRK pin can adjust the soft-start time ( $t_{SS}$ ) – provided the internal soft-start time of 500  $\mu$ s (Typ.) as a lower limit. The adjustable soft-start time ( $t_{SS2}$ ) is 1.6 ms (Typ.) when connecting an external capacitor of 4.7 nF with the charging current of 2.0  $\mu$ A (Typ.) and 0.64 V (Typ.). If not required to adjust the soft-start time, set the CSS/TRK pin to “Open” to enable the internal soft-start time ( $t_{SS1}$ ) of 500  $\mu$ s (Typ.). When a large-capacitance output capacitor is connected, the overcurrent protection may work due to an inflow of large current at startup. Thus, set a longer soft start time to reduce the amount of current and prevent from operating the protections due to the rapid startup. Each of soft-start time ( $t_{SS1}$ /  $t_{SS2}$ ) is guaranteed under the conditions described in the chapter of “*Electrical Characteristics*”.

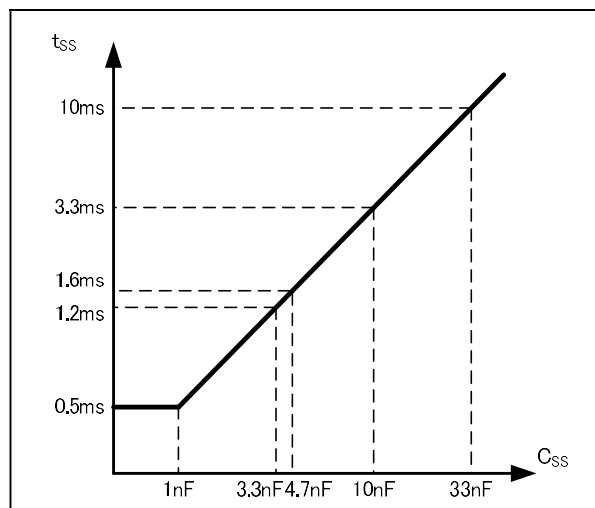

$$C_{SS} [nF] = (t_{SS} - t_{VO\_S}) / 0.64 \times 2.0$$

$t_{SS}$ : Soft-start time (ms)  
 $t_{VO\_S}$ : Time period from CE = “High” to VOUT’s rising (Typ. 0.160 ms)

**Soft-start Time Adjustment Capacitor vs Soft-start Time**

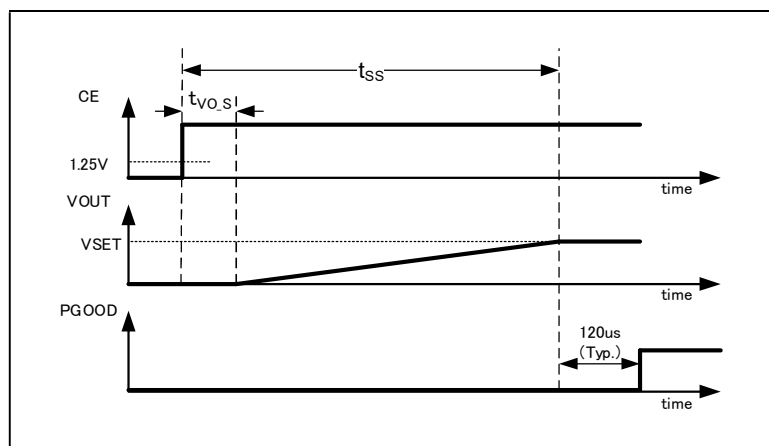

**Soft-start Sequence**

### Tracking Function

Applying an external tracking voltage to the CSS / TRK pin can control the soft-start sequence – provided that the lowest internal soft-start time is limited to 500  $\mu\text{s}$  (Typ.). Since  $V_{\text{FB}}$  becomes nearly equal to  $V_{\text{CSS/TRK}}$  at tracking, the complex start timing and soft-start can be easily designed. The available voltage at tracking is between 0 V and 0.64 V. If the tracking voltage is over 0.64 V, the internal reference voltage of 0.64 V is enabled. Also, an arbitrary falling waveform can be generated by reducing  $V_{\text{CSS/TRK}}$  to 0.64 V (Typ.) or less, because the R1278S supports both of up- and down- tracking.

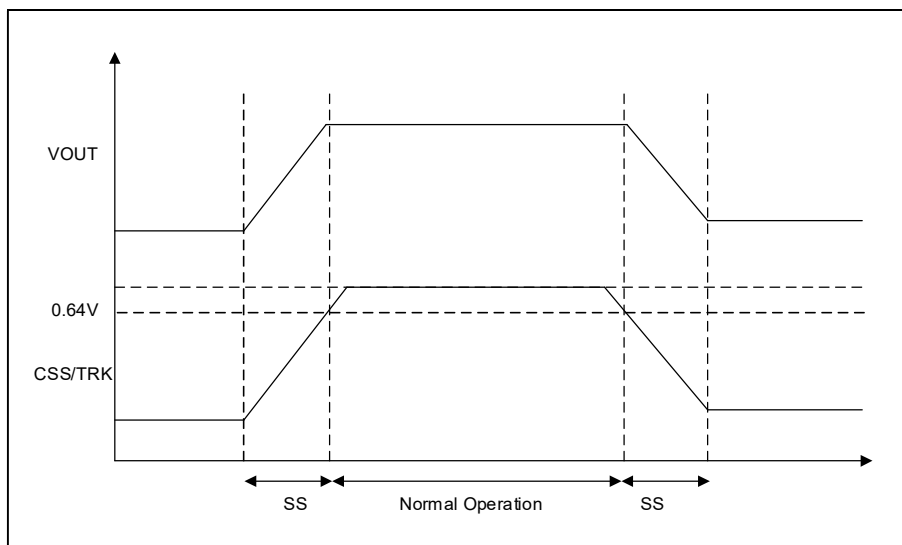

Tracking Sequence

### Reverse Current Limit

The reverse current limit starts operating when the reverse current flowing through the low-side transistor exceeds the set reverse current threshold. It turns off the low-side transistor to control the reverse current. The reverse current limit is 1.35 A (Typ.). This function operates when the output voltage is pulled up more than the set output voltage due to short-circuiting.

### SSCG (Spread Spectrum Clock Generator)

The SSCG function works for EMI reduction at the PWM mode. This function is enabled in the R1278S003C. This function makes EMI waveforms decrease in amplitude to generate a triangular waveform within approximately +10.0% (Typ.) of the oscillator frequency ( $f_{\text{osc}}$ ). The modulation cycle is  $f_{\text{osc}} / 128$ . SSCG is enabled only when MODE = High. SSCG is not effective when a clock is externally applied. The oscillator frequencies are not modulated during the soft-start.

**Bad Frequency Protection (BADFREQ)**

If a current equivalent to 4 MHz (Typ.) and more, or 125 kHz (Typ.) or less is applied to the RT pin when the oscillator frequency setting resistor ( $R_{RT}$ ) of the RT pin is in open / short, the R1278S will stop switching to protect the IC and will cause the internal state to transition to its state before the soft-start. The R1278S will restart under the normal control from the state of soft-start when recover after the abnormal condition.

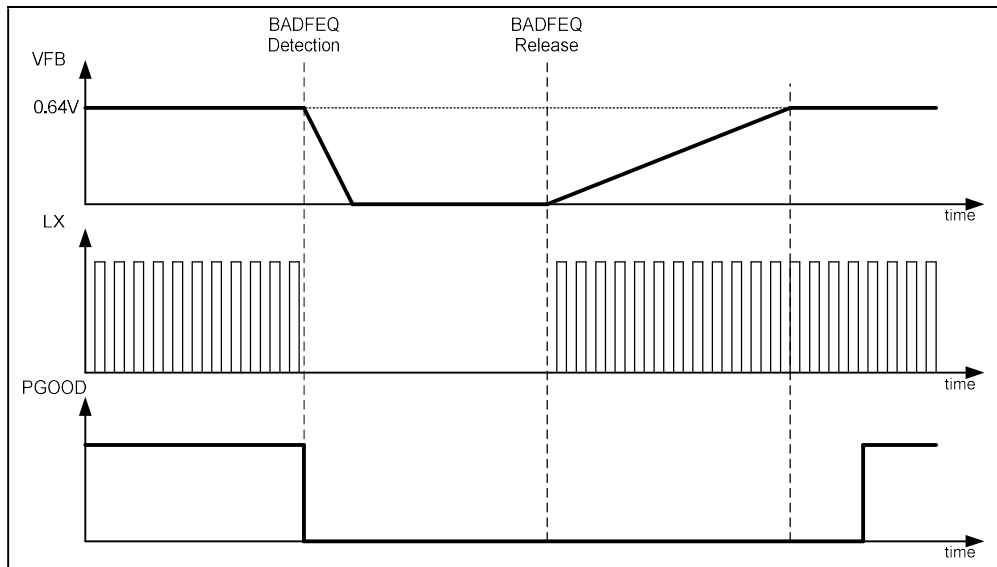
**BADFREQ Detection/ Release Sequence****Thermal Shutdown Function**

When the junction temperature exceeds the thermal shutdown detection threshold (Typ. 160°C), R1278S cuts off the output from DC/DC and suppresses the self-heating. When the junction temperature falls below the thermal shutdown release threshold (Typ. 140°C), the IC will restart with the soft start operation.

### Operation of Step-down DC/DC Converter

The basic operation of the step-down DC/DC converter is shown in the following figures.

This step-down DC/DC converter charges energy in the inductor while the high-side transistor turns on, and discharges the energy from the inductor when the high-side transistor turns off. This inductor reduces the energy loss to provide the lower output voltage ( $V_{OUT}$ ) than the input voltage ( $V_{IN}$ ).

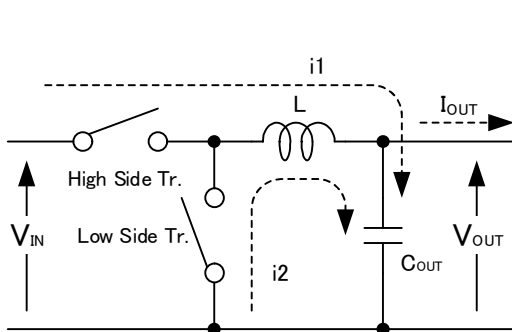

**Basic Circuit**

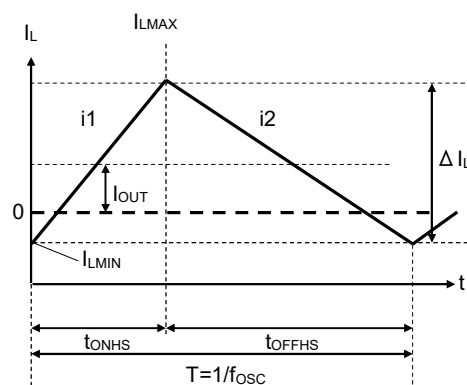

**Current Through Inductor**

- Step1. When the high-side transistor turns on, current  $I_L (= i1)$  flows through the  $L$  to charge  $C_{OUT}$  and provide  $I_{OUT}$ . At this moment,  $I_L = i1$  increases from  $I_{LMIN}$  to reach  $I_{LMAX}$  in proportion to the on-time period ( $t_{ONHS}$ ) of the high-side transistor.
- Step2. When the high-side transistor turns off, the low-side transistor turns on in order to maintain  $I_L$  at  $I_{LMAX}$ , and current  $I_L (= i2)$  flows.
- Step3. The low-side transistor turns on until going to the next cycle. Therefore, even if  $I_L = 0$ ,  $I_{LMIN} < 0$  may occur by keeping the low-side transistor "On".

In the PWM mode, the output voltage is maintained constant by controlling  $t_{ONHS}$  with the constant switching frequency ( $f_{OSC}$ ).



**Calculation of Inductor Current**

The peak inductor current  $I_{LMAX}$  can be estimated by the following equation.

$$I_{LMAX} = I_{OUT} + 1/2 \times (V_{IN} - V_{OUT}) / L \times V_{OUT} / V_{IN} / f_{OSC}$$

Example:  $I_{LMAX} = 1A + 1/2 \times (12V - 5V) / 2.2\mu H \times 5V / 12V / 2MHz$   
 $= 1.331 A$

The above can be calculated from the equation with the inductor current in continuous mode of a general step-down DC/DC converter. The P-P value of the inductor ripple current is “ $\Delta I_L$ ”.

The  $\Delta I_L$  is calculated by Equation 1 when the high side transistor is ON.

$$\Delta I_L = (V_{IN} - V_{OUT}) / L \times t_{ONHS} \dots\dots\dots \text{Equation 1}$$

The  $\Delta I_L$  is calculated by Equation 2 when the high side transistor is OFF.

$$\Delta I_L = V_{OUT} / L \times t_{OFFHS} \dots\dots\dots \text{Equation 2}$$

Using Equation 2 to Equation 1, the ON duty of the high side transistor  $t_{ONHS} / (t_{ONHS} + t_{OFFHS}) = D_{ON}$  is solved by Equation 3.

$$D_{ON} = V_{OUT} / V_{IN} \dots\dots\dots \text{Equation 3}$$

And then, the ripple current  $\Delta I_L$  is calculated by substituting  $t_{ONHS} = D_{ON} / f_{OSC}$  into Equation 1.

$$\Delta I_L = (V_{IN} - V_{OUT}) / L \times D_{ON} / f_{OSC} \dots\dots\dots \text{Equation 4}$$

At this time,  $I_{LMAX}$  flowing in the inductor and high side transistor is calculated by Equation 5.

$$I_{LMAX} = I_{OUT} + \Delta I_L / 2 \dots\dots\dots \text{Equation 5}$$

Therefore  $I_{LMIN}$  is calculated by Equation 6.

$$I_{LMIN} = I_{OUT} - \Delta I_L / 2 \dots\dots\dots \text{Equation 6}$$

Note that the input-output conditions and peripheral components should be determined in consideration of  $I_{LMAX}$  and  $I_{LMIN}$ .

The above calculations are based on the ideal operation in continuous mode.

### Forced PWM Mode

The R1278S goes into the forced PWM mode by setting the MODE pin “High” or applying the external clock to the MODE pin. The forced PWM mode operates at fixed switching frequency even during the light load in order to reduce noise. Therefore, when the output current ( $I_{OUT}$ ) is less than  $\Delta I_L / 2$ ,  $I_{LMIN}$  becomes less than “0”. That is, the electric charge, which is charged to  $C_{OUT}$ , is discharged via transistor for the durations – when  $I_L$  reaches “0” from  $I_{LMIN}$  during the  $t_{ONHS}$  periods and when  $I_L$  reaches  $I_{LMIN}$  from “0” during  $t_{OFFHS}$  periods. But, pulses are skipped to prevent the overvoltage when high-side transistor is set to ON under the condition that the output voltage being more than the set output voltage.

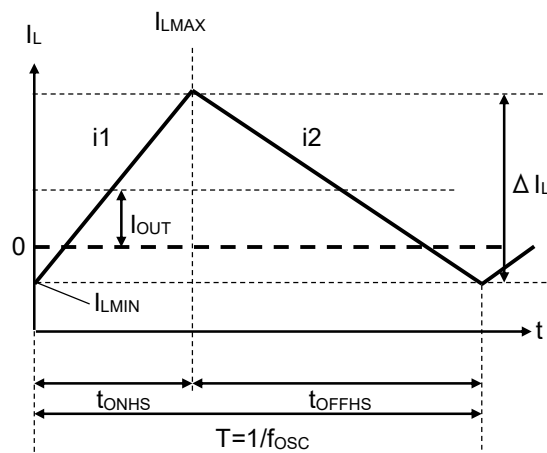

Forced PWM Mode

## TECHNICAL NOTES

The performance of a power source circuit using this device is highly dependent on a peripheral circuit. A peripheral component or the device mounted on PCB should not exceed a rated voltage, a rated current or a rated power. When designing a peripheral circuit, please be fully aware of the following points.

- External components must be connected as close as possible to the ICs and make wiring as short as possible. Especially, the capacitor connected in between VIN pin and GND pin must be wiring the shortest. If their impedance is high, internal voltage of the IC may shift by the switching current, and the operating may be unstable. Make the power supply and GND lines sufficient.
- Place a capacitor ( $C_{BST}$ ) as close as possible to the LX pin and the BST pin. If controlling slew rate for EMI, a resistor ( $R_{BST}$ ) should be in series between the BST pin and the capacitor ( $C_{BST}$ ).
- The tab on the bottom of the HSOP-18 package must be connected to GND when mounted on the board. To improve thermal dissipation on the multilayer board, set via to release the heat to the other layer in the connecting part of the tab on the bottom.
- The NC pin must be set to “Open”.
- The MODE pin requires the high voltages with the high stability when the forced PWM mode (MODE = “High”) is enabled. If the voltage with the high stability cannot be applied, connection to the VCC pin as “High” level is recommended. Avoid the use of the MODE pin being “GND” or “Open”.
- If  $V_{OUT}$  is a minus potential, the setup cannot occur.
- Shorten the wiring between the Lx pin and the inductor so that the parasitic capacitance is not provided.
- It is recommended to place the input capacitor ( $C_{IN}$ ) on the same side as the IC. If it is placed on the different side as the IC by using via, the noise may be increased due to the parasitic inductance component of via.
- Feedback the output voltage near the  $C_{OUT}$ .
- Place  $R_{TOP}$ ,  $R_{BOT}$ , and  $C_{SPD}$  near FB pin and mount them at a position apart from the inductor, Lx pin, and BST pin to prevent the effect of noise.
- The thermal shutdown function prevents the IC from fuming and ignition but does not ensure the IC’s reliability or keep the IC below the absolute maximum ratings. The thermal shutdown function does not operate on the heat generated by other than the normal IC operation such as latch-up and overvoltage application.
- The thermal shutdown function operates in a state over the absolute maximum ratings, therefore the thermal shutdown function should not be used for a system design.

# APPLICATION INFORMATION

## PCB LAYOUT

### R1278S

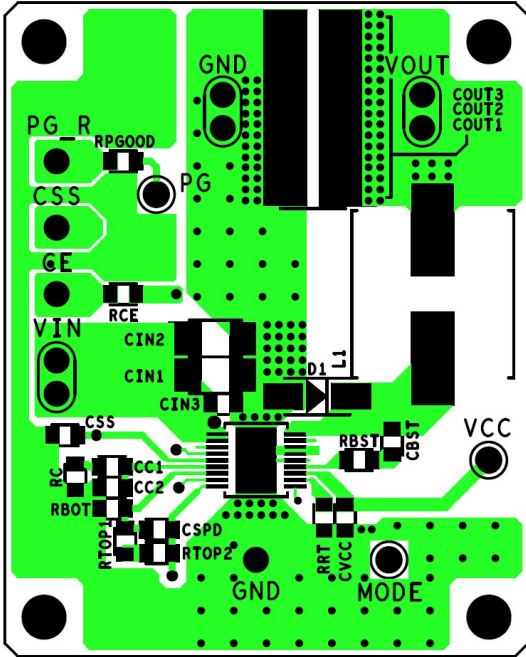

Layer 1 (Top)

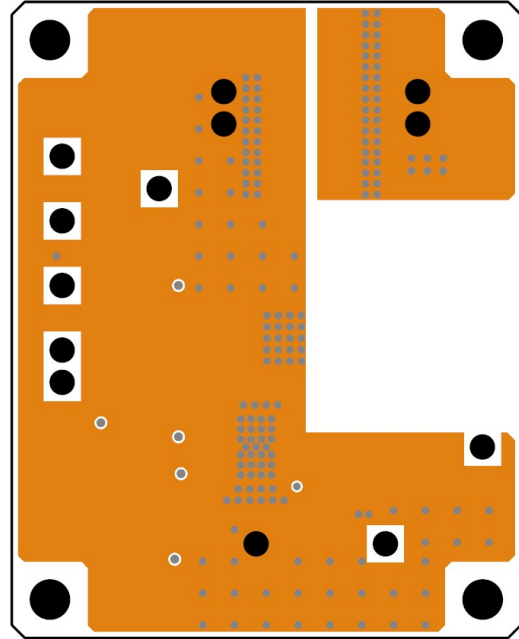

Layer 2

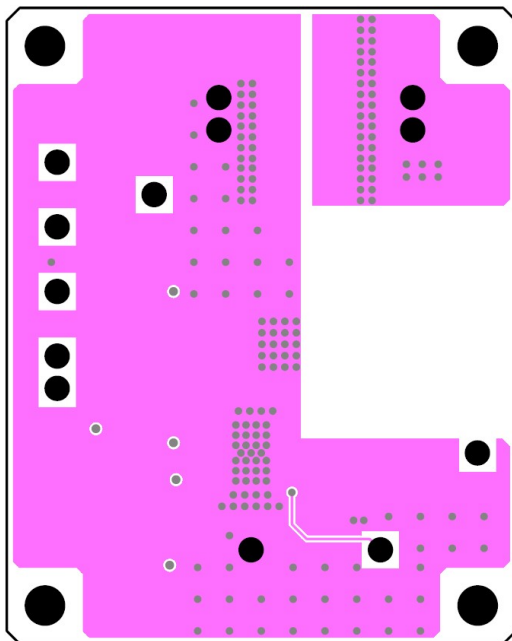

Layer 3

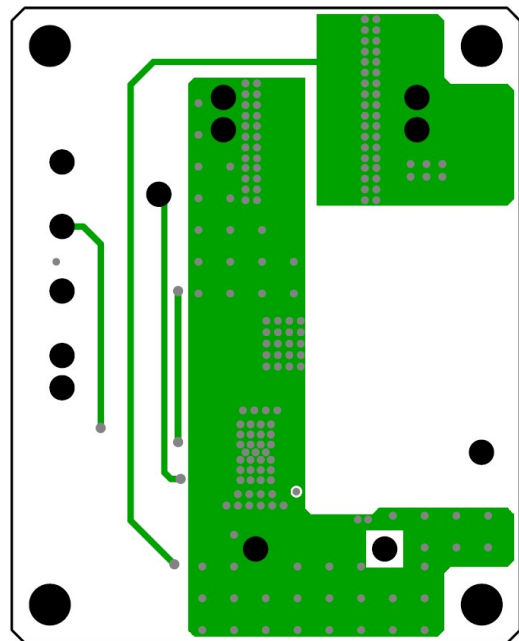

Layer 4 (Bottom)

## TYPICAL CHARACTERISTICS

Note: Typical Characteristics are intended to be used as reference data; they are not guaranteed.

### 1) FB Voltage

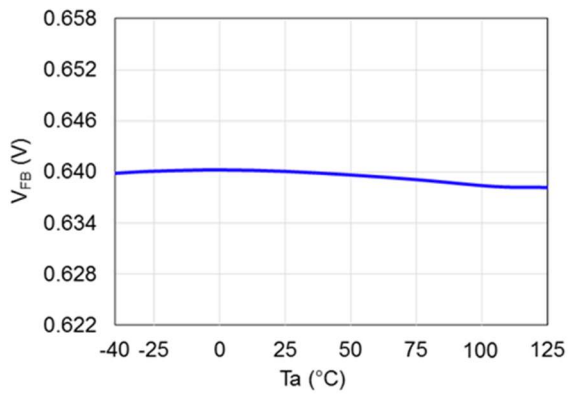

### 2) Oscillator Frequency 0

2 MHz ( $R_{RT} = 14 \text{ k}\Omega$ )

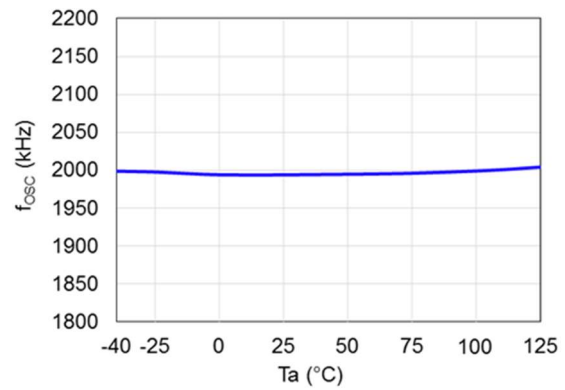

### 3) Soft-start Time

Internally Fixed Soft-start Time

( $C_{SS} = \text{Open}$ )

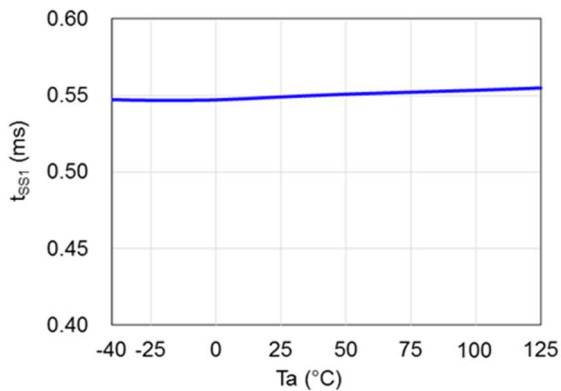

Externally Adjustable Soft-start Time

( $C_{SS} = 4.7 \text{ nF}$ )

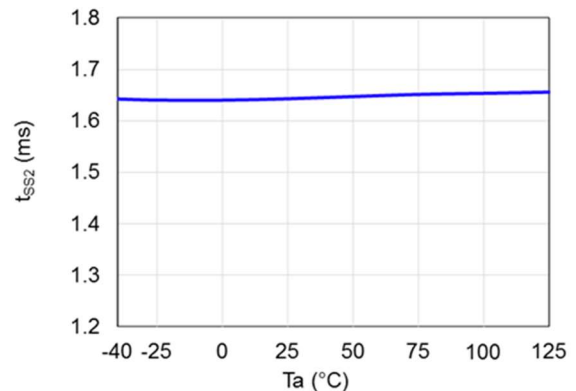

### 4) LX Limit Current

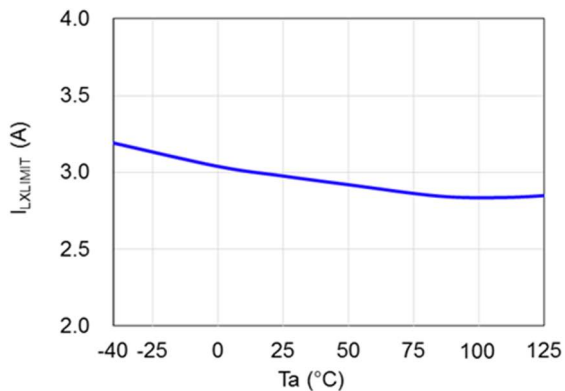

### 5) VIN Consumption Current 1

$V_{IN} = 12 \text{ V}$ , MODE = H

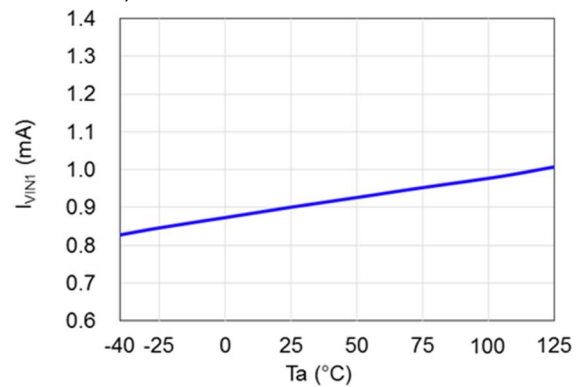

6) UVLO

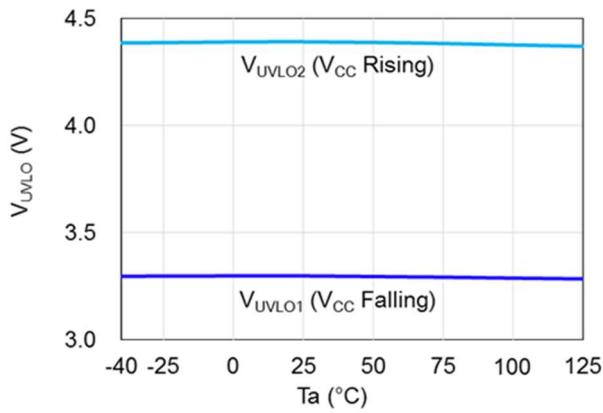

7) CE Input Voltage

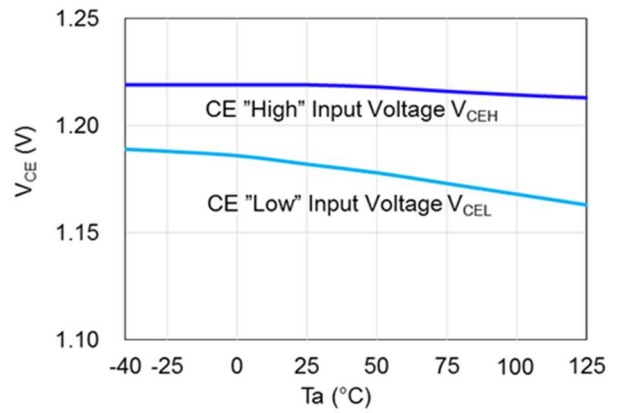

8) Efficiency

$V_{OUT} = 3.3\text{ V}$ ,  $f_{osc} = 2\text{ MHz}$ ,  $T_a = 25^\circ\text{C}$

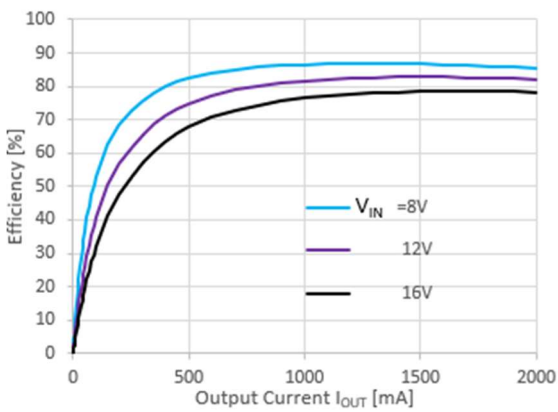

$V_{OUT} = 5.0\text{ V}$ ,  $f_{osc} = 2\text{ MHz}$ ,  $T_a = 25^\circ\text{C}$

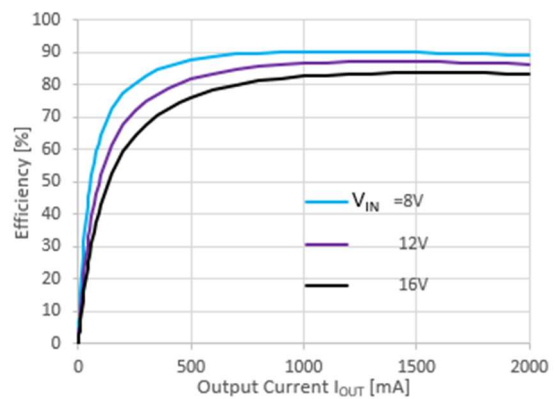

9) Load Transient Response

$V_{IN} = 12\text{ V}$ ,  $V_{OUT} = 3.3\text{ V}$ ,  $f_{osc} = 2\text{ MHz}$ ,  
MODE = H,  $T_a = 25^\circ\text{C}$

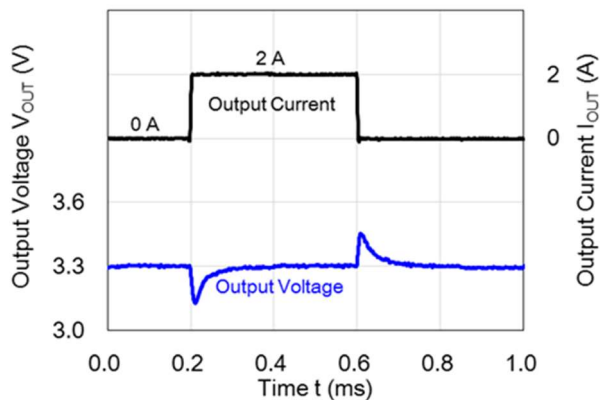

**10) Load Regulation**

$V_{OUT} = 3.3\text{ V}$ ,  $f_{OSC} = 2\text{ MHz}$

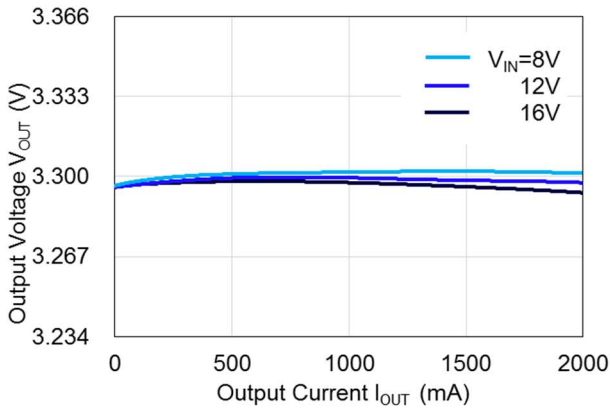

$V_{OUT} = 5.0\text{ V}$ ,  $f_{OSC} = 2\text{ MHz}$

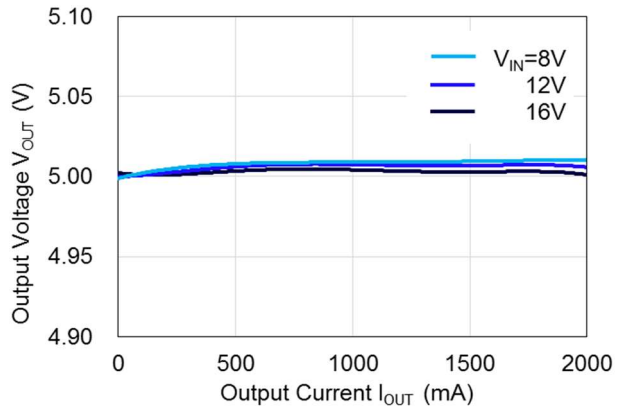

**11) Input Voltage Transient Response**

$V_{IN} = 8\text{ V} \rightarrow 16\text{ V}$ ,  $t_r = t_f = 100\ \mu\text{s}$

$V_{OUT} = 3.3\text{ V}$ ,  $f_{OSC} = 2\text{ MHz}$ ,  $I_{OUT} = 1\text{ A}$

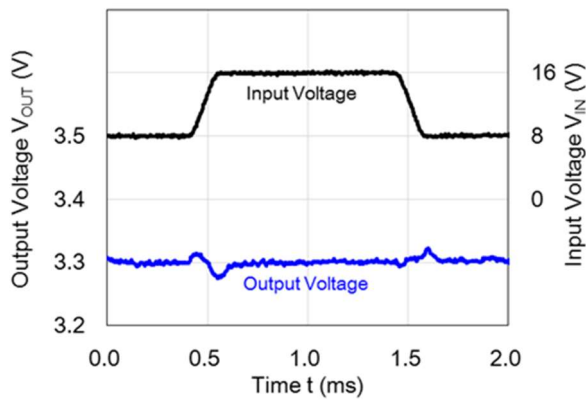

**12) Line Regulation**

$V_{OUT} = 3.3\text{ V}$ ,  $f_{OSC} = 2\text{ MHz}$

$I_{OUT} = 1\text{ A}$ ,  $T_a = 25^\circ\text{C}$

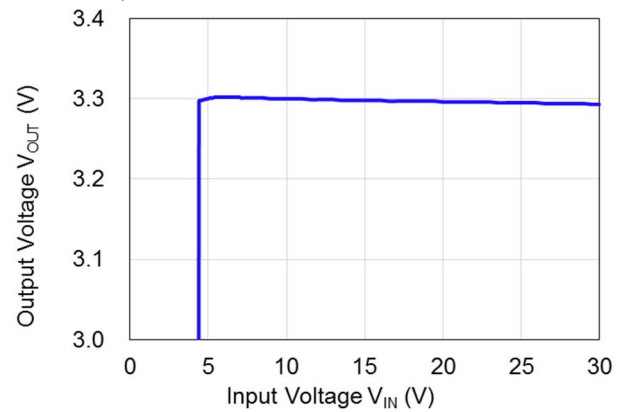

**13) Transient Voltage Surge**

$V_{OUT} = 3.3\text{ V}$ ,  $f_{OSC} = 2\text{ MHz}$

$I_{OUT} = 100\text{ mA}$ ,  $T_a = 25^\circ\text{C}$

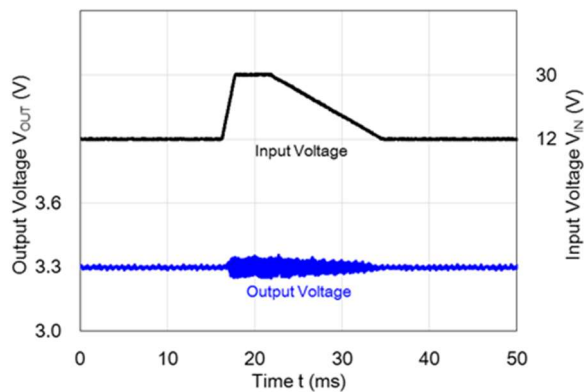

**14) Cranking**

$V_{OUT} = 5.0V$ ,  $f_{osc} = 2MHz$ ,  $I_{OUT} = 100mA$ ,  $T_a = 25^\circ C$

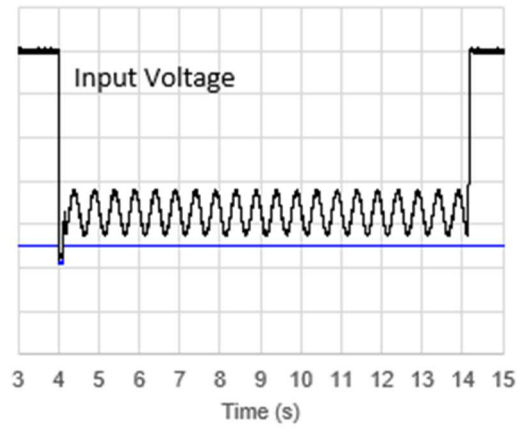
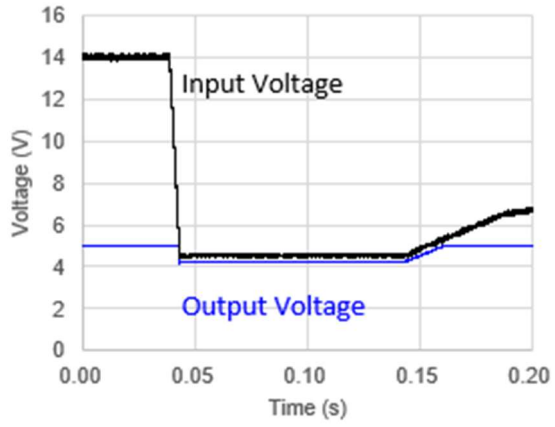



## Test Circuit

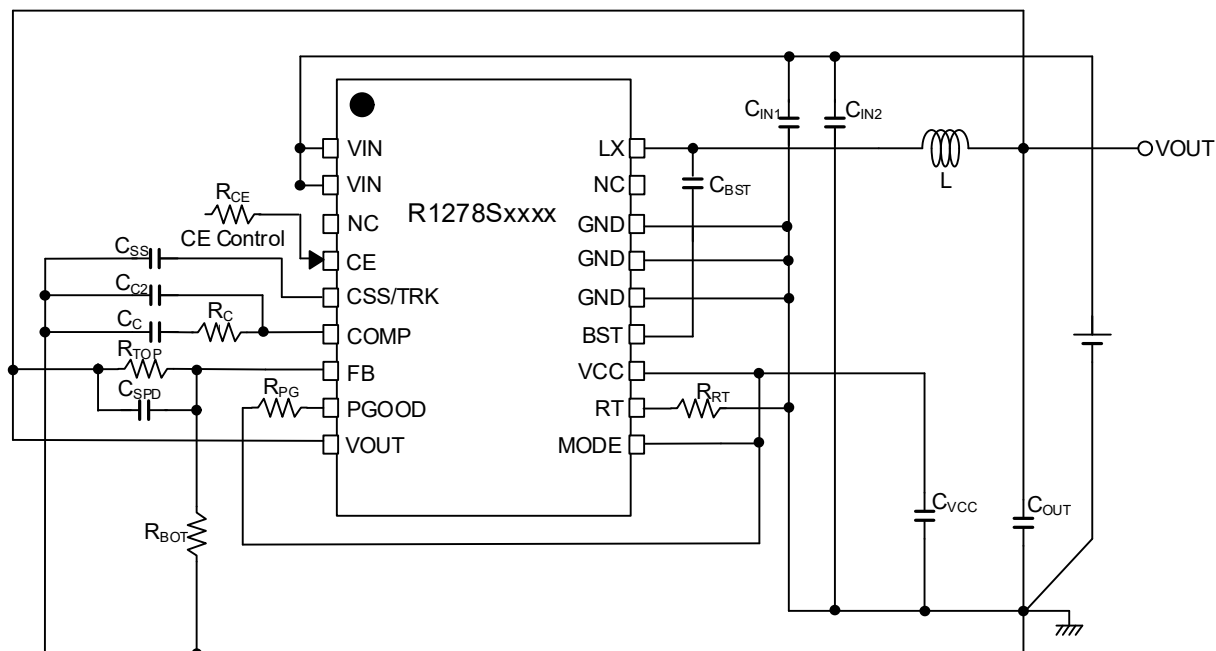

Test Circuit for Typical Characteristics

## Measurement Components for Typical Characteristics

Symbol	Capacitance	Tolerance	Voltage resistance	Temperature characteristics	Parts number
C <sub>IN1</sub>	1.0 $\mu$ F	$\pm 10\%$	50 V	X7R	CGA4J3X7R1H105K (TDK)
C <sub>IN2</sub>	10 $\mu$ F	$\pm 10\%$	50 V	X7S	CGA6P3X7S1H106K (TDK)
C <sub>OUT</sub>	4.7 $\mu$ F	$\pm 10\%$	25 V	X7R	CGA5L1X7R1E475K (TDK)
	22 $\mu$ F	$\pm 20\%$	16 V	X7R	CGA6P1X7R1C226M (TDK)
C <sub>BST</sub>	0.1 $\mu$ F	$\pm 10\%$	25 V	X7R	CGA3E2X7R1E104K (TDK)
C <sub>VCC</sub>	1.0 $\mu$ F	$\pm 10\%$	16 V	X7R	CGA3E1X7R1C105K (TDK)

Symbol	Inductance	Tolerance	Rated current	Parts number
L	2.2 $\mu$ H	$\pm 30\%$	5.5 A	CLF7045NIT-2R2-D (TDK)

The power dissipation of the package is dependent on PCB material, layout, and environmental conditions. The following measurement conditions are based on JEDEC STD. 51-7.

**Measurement Conditions**

Item	Measurement Conditions
Environment	Mounting on Board (Wind Velocity = 0 m/s)
Board Material	Glass Cloth Epoxy Plastic (Four-Layer Board)
Board Dimensions	76.2 mm × 114.3 mm × 0.8 mm
Copper Ratio	Outer Layer (First Layer): Less than 95% of 50 mm Square Inner Layers (Second and Third Layers): Approx. 100% of 50 mm Square Outer Layer (Fourth Layer): Approx. 100% of 50 mm Square
Through-holes	φ 0.3 mm × 21 pcs

**Measurement Result**

(Ta = 25°C, Tjmax = 150°C)

Item	Measurement Result
Power Dissipation	3900 mW
Thermal Resistance ( $\theta_{ja}$ )	$\theta_{ja} = 32^\circ\text{C/W}$
Thermal Characterization Parameter ( $\psi_{jt}$ )	$\psi_{jt} = 8^\circ\text{C/W}$

$\theta_{ja}$ : Junction-to-Ambient Thermal Resistance

$\psi_{jt}$ : Junction-to-Top Thermal Characterization Parameter

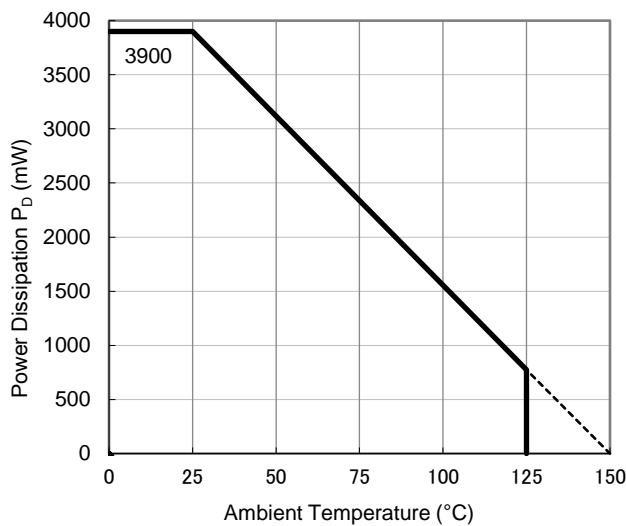

**Power Dissipation vs. Ambient Temperature**

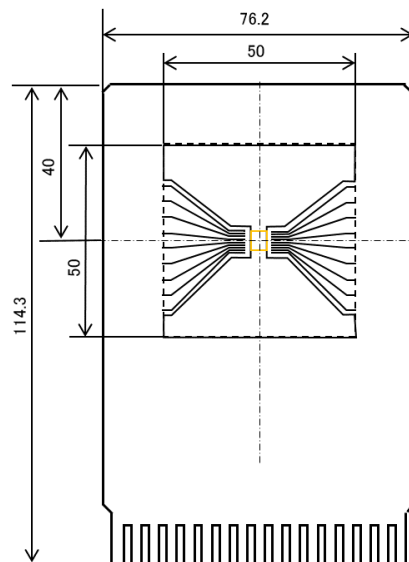

**Measurement Board Pattern**

# PACKAGE DIMENSIONS

# HSOP-18

DM-HSOP-18-JE-B

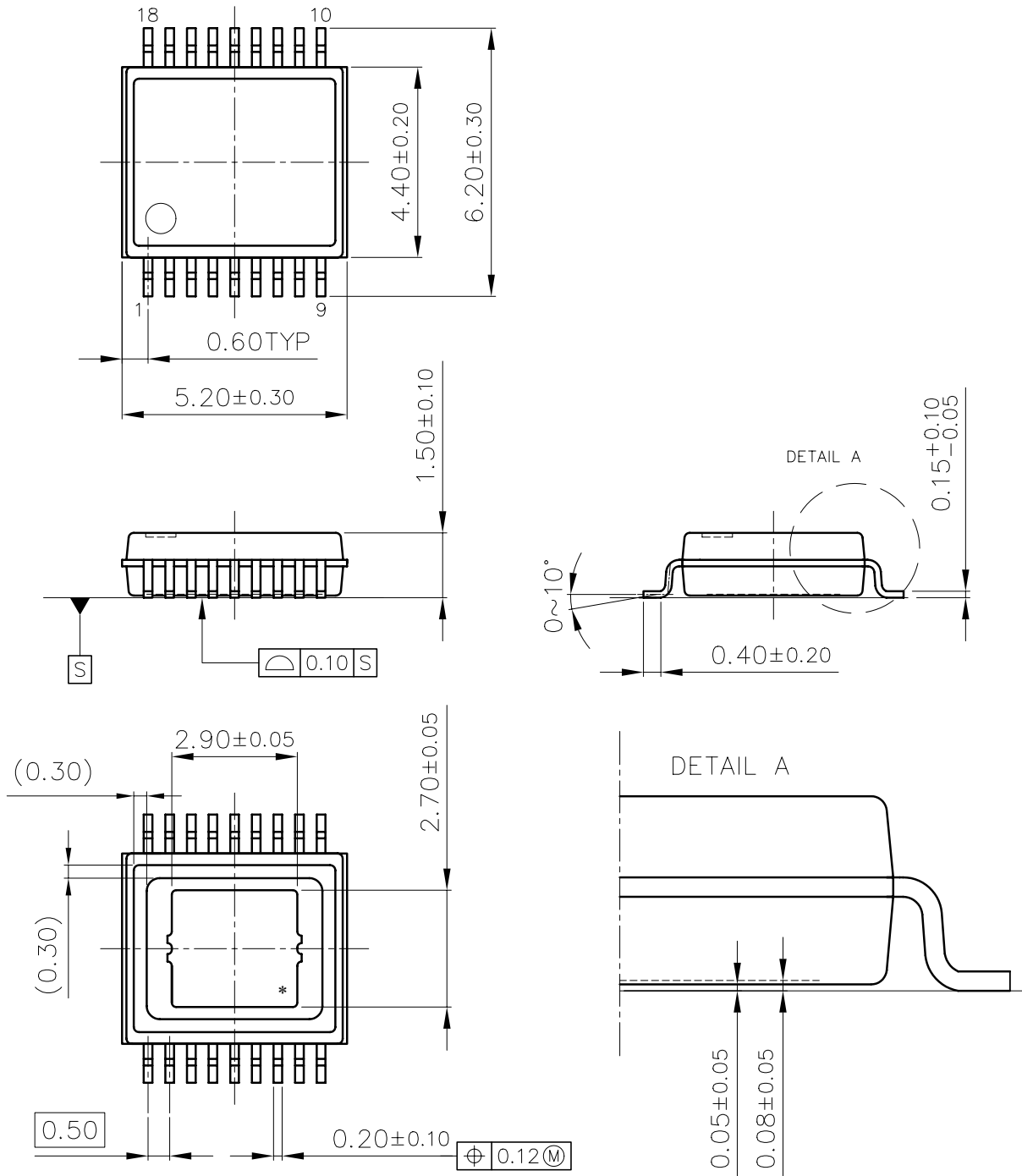

UNIT: mm

HSOP-18 Package Dimensions



1. The products and the product specifications described in this document are subject to change or discontinuation of production without notice for reasons such as improvement. Therefore, before deciding to use the products, please refer to Ricoh sales representatives for the latest information thereon.
2. The materials in this document may not be copied or otherwise reproduced in whole or in part without prior written consent of Ricoh.
3. Please be sure to take any necessary formalities under relevant laws or regulations before exporting or otherwise taking out of your country the products or the technical information described herein.
4. The technical information described in this document shows typical characteristics of and example application circuits for the products. The release of such information is not to be construed as a warranty of or a grant of license under Ricoh's or any third party's intellectual property rights or any other rights.
5. The products in this document are designed for automotive applications. However, when using the products for automotive applications, please make sure to contact Ricoh sales representative in advance due to confirming the quality level.
6. We are making our continuous effort to improve the quality and reliability of our products, but semiconductor products are likely to fail with certain probability. In order to prevent any injury to persons or damages to property resulting from such failure, customers should be careful enough to incorporate safety measures in their design, such as redundancy feature, fire containment feature and fail-safe feature. We do not assume any liability or responsibility for any loss or damage arising from misuse or inappropriate use of the products.
7. Anti-radiation design is not implemented in the products described in this document.
8. The X-ray exposure can influence functions and characteristics of the products. Confirm the product functions and characteristics in the evaluation stage.
9. WLCSP products should be used in light shielded environments. The light exposure can influence functions and characteristics of the products under operation or storage.
10. There can be variation in the marking when different AOI (Automated Optical Inspection) equipment is used.  
In the case of recognizing the marking characteristic with AOI, please contact Ricoh sales or our distributor before attempting to use AOI.
11. Please contact Ricoh sales representatives should you have any questions or comments concerning the products or the technical information.



**Ricoh is committed to reducing the environmental loading materials in electrical devices with a view to contributing to the protection of human health and the environment.**

Ricoh has been providing RoHS compliant products since April 1, 2006 and Halogen-free products since April 1, 2012.

**RICOH** RICOH ELECTRONIC DEVICES CO., LTD.

**Official website**

<https://www.n-redc.co.jp/en/>

**Contact us**

<https://www.n-redc.co.jp/en/buy/>

