

## Product brief

# XENSIV™ – IM67D130A Automotive MEMS microphone

## AEC-Q103-003 qualified MEMS microphone

The Infineon IM67D130A is an automotive qualified high performance MEMS microphone for automotive applications. The device has a digital interface and a PG-LLGA-5-4 package.

The product is designed for applications where low self-noise (high SNR), wide dynamic range, low distortions and a high acoustic overload point is required. Infineon's Dual Backplate MEMS technology is based on a miniaturized symmetrical microphone design, similar as utilized in studio condenser microphones, and results in high linearity of the output signal within a high dynamic range. The microphone distortion (THD) does not exceed 1 percent even up to very high sound pressure levels (SPL). The flat frequency response and tight manufacturing tolerance results in close sensitivity and phase matching of the microphones, which is important for multi-microphone (array) applications.

With its low equivalent noise floor the microphone is no longer the limiting factor in the audio signal chain and enables higher performance of voice recognition algorithms. The digital microphone ASIC contains an extremely low-noise preamplifier and a high-performance sigma-delta ADC. Different power modes can be selected in order to suit specific current consumption requirements.

Each device is calibrated with an advanced Infineon calibration algorithm, resulting in small sensitivity tolerances. The phase response is tightly matched between microphones, in order to support beam-forming applications.

### Block diagram

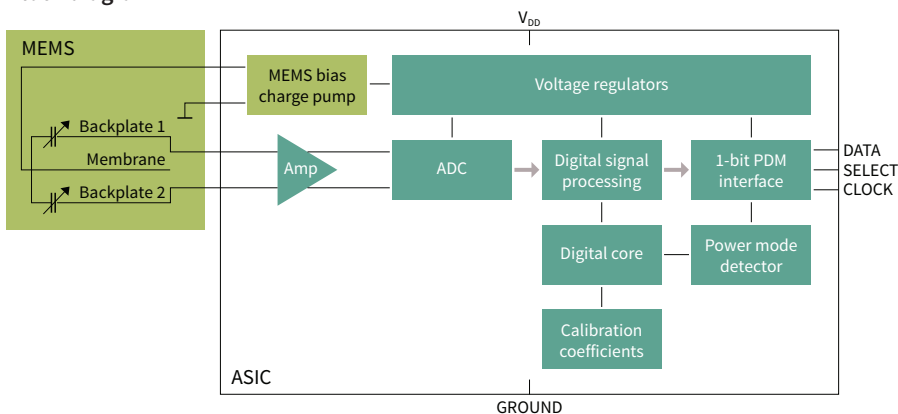

### Key features

- > High dynamic range of 103 dB for best speech performance
- > Signal to noise ratio of 67 dB(A)
- > <1 percent total harmonic distortions up to high SPL levels
- > Acoustic overload point at 130 dB SPL
- > Increased operating temperature range:  $T_A = -40^{\circ}\text{C} \dots 105^{\circ}\text{C}$
- > Digital PDM output
- > Qualification according to AEC-Q103-003

### Key benefits

- > Close sensitivity and phase matching for usage in arrays
- > Extended availability to match long automotive design cycles
- > Flat frequency response with low frequency roll off and small group delay for best ANC performance
- > Enlarged operating temperature range allows flexible use in different application environments

### Key applications

- > Hands free calling
- > Emergency call systems (eCall)
- > Voice control/command
- > Active noise cancellation (ANC/RNC)
- > Siren detection
- > Road condition detection



# XENSIV™– IM67D130A Automotive MEMS microphone

## AEC-Q103-003 qualified MEMS microphone

Application diagram – Application circuit for “Typical stereo application circuit”

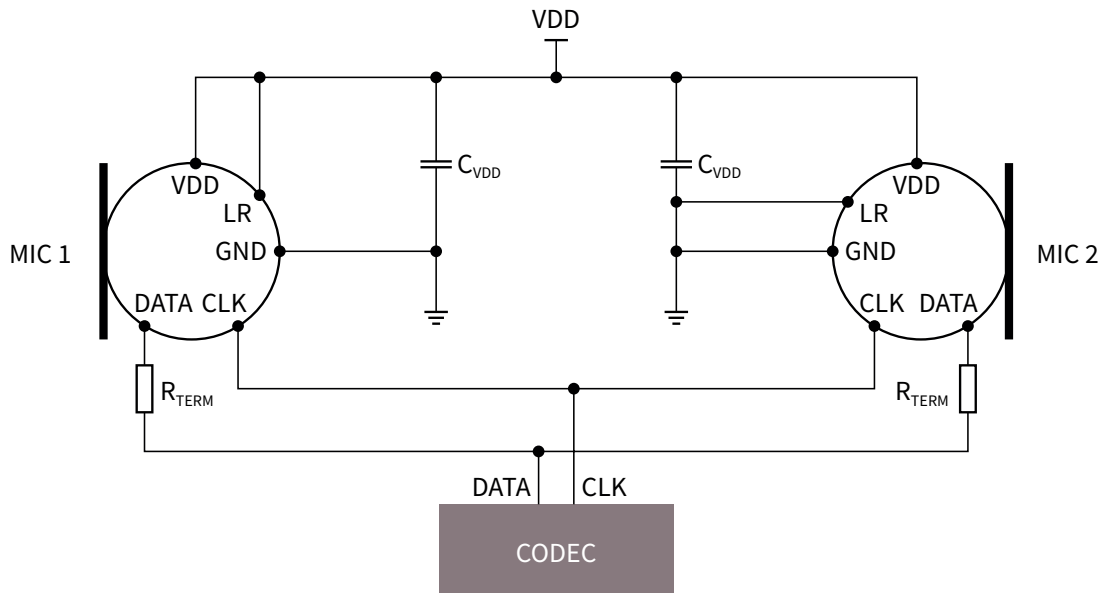

### Product table

Parametrics	IM67D130A
Acoustic overload point	130 dB SPL
Current consumption	980 µA
Interfaces	PDM
Sensitivity	-36 dBFS
Signal to noise	>67 dB(A)
Supply voltage	1.62 – 3.6 V
SP-Nr.	SP005447450

Published by  
Infineon Technologies AG  
81726 Munich, Germany

© 2021 Infineon Technologies AG.  
All Rights Reserved.

**Please note!**

This Document is for information purposes only and any information given herein shall in no event be regarded as a warranty, guarantee or description of any functionality, conditions and/or quality of our products or any suitability for a particular purpose. With regard to the technical specifications of our products, we kindly ask you to refer to the relevant product data sheets provided by us. Our customers and their technical departments are required to evaluate the suitability of our products for the intended application.

We reserve the right to change this document and/or the information given herein at any time.

**Additional information**

For further information on technologies, our products, the application of our products, delivery terms and conditions and/or prices, please contact your nearest Infineon Technologies office ([www.infineon.com](http://www.infineon.com)).

**Warnings**

Due to technical requirements, our products may contain dangerous substances. For information on the types in question, please contact your nearest Infineon Technologies office.

Except as otherwise explicitly approved by us in a written document signed by authorized representatives of Infineon Technologies, our products may not be used in any life-endangering applications, including but not limited to medical, nuclear, military, life-critical or any other applications where a failure of the product or any consequences of the use thereof can result in personal injury.