

31VPP OUTPUT PIEZO SOUNDER DRIVER WITH BOOST CONVERTER
Description

The PAM8907 is a piezoelectric horn driver with built-in boost converter, capable of driving a ceramic/piezo sounder with up to 31V_{PP} output. With integrated boost converter, the PAM8907 can provide an optimized solution with higher Sound Pressure Level (SPL) for louder output sound, lower quiescent current for longer standby time, and auto turn-on/off feature for extended operating lifetime. The PAM8907 provides clear benefits for battery-operated tracker, piezoelectric horn or alarm related applications.

The PAM8907 integrates a boost converter that operates at a typical frequency of 1.8MHz. With integrated boost converter and unique piezo sounder driver technology, the PAM8907 provides small inrush current, low EMI and yet highly efficient system performance. PAM8907 Boost converter output can be set to either 11V or 15.6V with minimum external components for various application usages.

The PAM8907 has built-in automatic shutdown and wake-up functions for longer operating lifetime requirement. It also features thermal shutdown protection, over-current protection, over-voltage protection and under-voltage-lockout protection to assure safe system operation.

The PAM8907 is available in U-QFN2020-10 package.

Features

- Supply Voltage Range from 1.8V to 5.5V
- Intergrated Boost Converter V_{OUT} = 11V or 15.6V
- Drive Piezo Sounder with up to 31V_{PP}
- High-Speed Driver Designed with Very Short Turn-On/Turn-Off
- No Voltage Cross Output at Shutdown Mode
- High Impedence Output at Shutdown Mode
- Low Current Consumption, with Shutdown Current < 1μA
- Automatic Shutdown and Wake-Up Control
- Available in Space-Saving U-QFN2020-10 package
- **Totally Lead-Free & Fully RoHS Compliant (Notes 1 & 2)**
- **Halogen and Antimony Free. "Green" Device (Note 3)**
- **For automotive applications requiring specific change control (i.e. parts qualified to AEC-Q100/101/200, PPAP capable, and manufactured in IATF 16949 certified facilities), please [contact us](https://www.diodes.com/quality/product-definitions/) or your local Diodes representative.**

<https://www.diodes.com/quality/product-definitions/>

- Notes:
1. No purposely added lead. Fully EU Directive 2002/95/EC (RoHS), 2011/65/EU (RoHS 2) & 2015/863/EU (RoHS 3) compliant.
 2. See <https://www.diodes.com/quality/lead-free/> for more information about Diodes Incorporated's definitions of Halogen- and Antimony-free, "Green" and Lead-free.
 3. Halogen- and Antimony-free "Green" products are defined as those which contain <900ppm bromine, <900ppm chlorine (<1500ppm total Br + Cl) and <1000ppm antimony compounds.

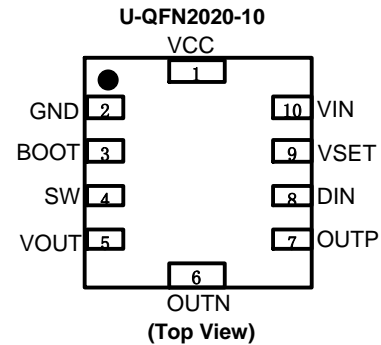
Pin Assignments

Applications

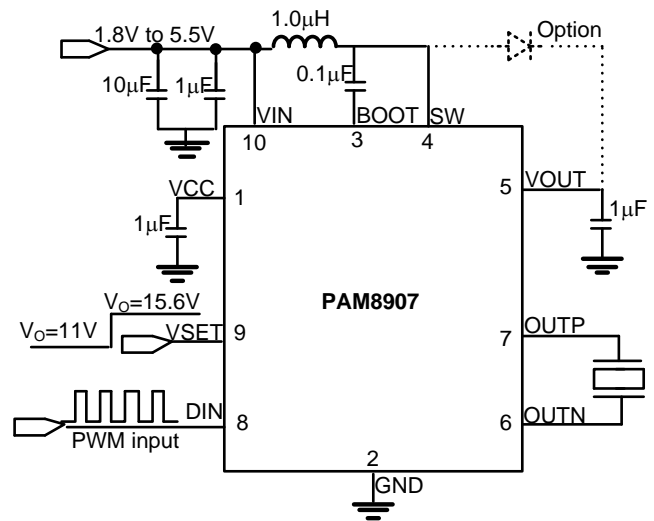
- Bluetooth or Wireless Location Tracker
- Air Humidifier or Ultrasonic Related Piezo Driver Application
- Security Devices, Home Appliances
- Haptic Feedback

Typical Applications Circuit

Note: Schottky diode is optional. If added, it can save 20% of power consumption.

Pin Descriptions

Pin Number	Pin Name	I/O/P	Function
1	VCC	O	LDO Output
2	GND	P	Ground
3	BOOT	O	Bootstrap Cap Connection
4	SW	I/O	Switch Pin Connect with External Inductor Pin
5	VOUT	O	Boost Output
6	OUTN	O	Negative Output
7	OUTP	O	Positive Output
8	DIN	I	PWM Signal Input, then End Signal Should be "L" to Disable the Chip
9	VSET	I	TTL Low $V_{OUT} = 11V$, TTL High $V_{OUT} = 15.6V$
10	VIN	I	Battery Voltage Input
—	Epoxy Pad	P	Connect to GND

Functional Block Diagram

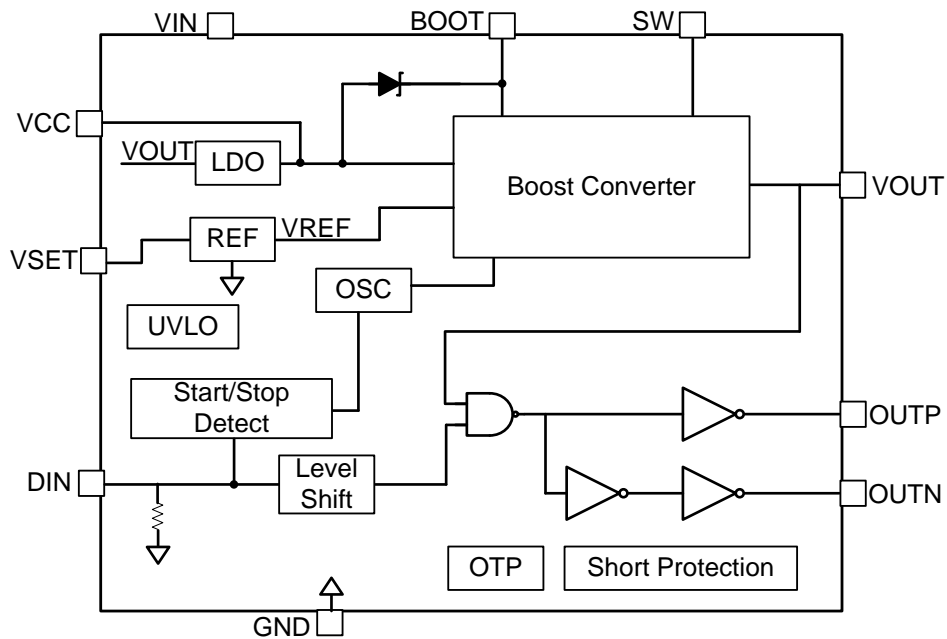

Absolute Maximum Ratings (@ $T_A = +25^\circ\text{C}$, unless otherwise specified.)

Symbol	Characteristics	Value	Unit
V_{IN}	Supply Voltage	-0.3 to 6.0	V
V_{IH}	High-Level Input Voltage	-0.3 to 6.0	V
V_{IL}	Low-Level Input Voltage	-0.3 to 6.0	V
T_A	Operating Free-Air Temperature Range	-40 to +125	$^\circ\text{C}$
T_J	Operating Junction Temperature Range	-40 to +150	$^\circ\text{C}$
T_{STG}	Storage Temperature Range	-65 to +150	$^\circ\text{C}$

Recommended Operating Conditions (@ $T_A = +25^\circ\text{C}$, unless otherwise specified.)

Symbol	Characteristics	Min	Max	Unit
V_{IN}	Supply Voltage	—	5.5	V
V_{IH}	High-Level Input Voltage	DIN		V
V_{IL}	Low-Level Input Voltage	DIN		V
T_A	Operating Free-Air Temperature	-40	+85	$^\circ\text{C}$

Thermal Information

Parameter	Symbol	Package	Maximum	Unit
Thermal Resistance (Junction to Ambient)	θ_{JA}	U-QFN2020-10	68	$^\circ\text{C}/\text{W}$
Thermal Resistance (Junction to Case)	θ_{JC}	U-QFN2020-10	25	$^\circ\text{C}/\text{W}$

Electrical Characteristics (@ $T_A = +25^\circ\text{C}$, $V_{IN} = 3.0\text{V}$, $C_{PIEZO} = 33\text{nF}$, $f_{DIN} = 3.2\text{kHz}$, unless otherwise specified.)

Parameter	Symbol	Conditions	Min	Typ	Max	Unit
Supply Voltage	V_{IN}	—	1.8	—	5.5	V
Output Voltage Range	V_{OUT}	Boost Output Voltage (VSET Pin L/H)	—	11 15.6	—	V
Shutdown Current	I_{SD}	$V_{DIN} = 0\text{V}$	0	0.03	1	μA
Oscillating Frequency	f_{OSC}	Boost Frequency	—	1.8	—	MHz
Static Drain to Source On-State Resistor	$R_{DS(ON)}$	High Side, $I = 100\text{mA}$ Low Side, $I = 100\text{mA}$	—	7.5 3	—	Ω
V_{OUT} Start Delay Time	t_{ON}	From DIN Signal High to 90% V_{OUT} Steady State	—	1.1	—	ms
Shutdown Delay Time	t_{OFF}	From $DIN = H \rightarrow L$, V_{OUT} to GND	—	104	—	ms
Output Short-Circuit Current	I_{SC}	OUTP and OUTN short	—	14	—	mA
Control Terminal Voltage H	V_{IH}	DIN Pin	1.5	—	V_{IN}	V
Control Terminal Voltage L	V_{IL}	DIN Pin	0	—	0.4	V
Control Terminal Current H	I_{IH}	$DIN = V_{IN}$	—	2	10	μA
Control Terminal Current L	I_{IL}	$DIN = 0$	—	0.01	1	μA
Over Temperature Threshold	OTP	—	—	+150	—	$^\circ\text{C}$
Over Temperature Protection Hysteresis	—	—	—	+30	—	$^\circ\text{C}$

Performance Characteristics ($V_{DD} = 3V$, $f_{DIN} = 3.2kHz$, $V_{SET} = L/H$, $C_{LOAD} = 15nF/33nF$, unless otherwise specified.)

1. Turn-on waveform at $V_{OUT} = 11V$

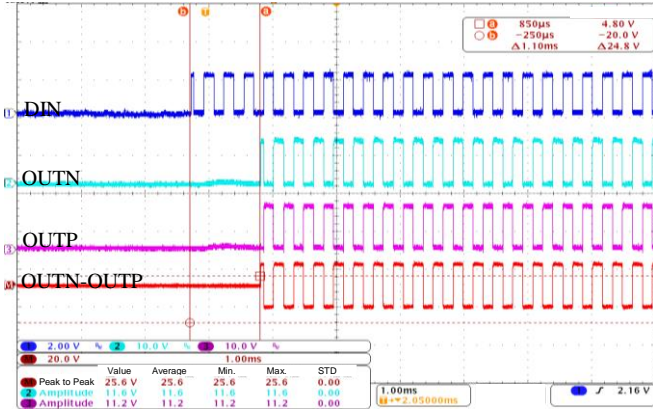

2. Turn-on waveform at $V_{OUT} = 15.6V$

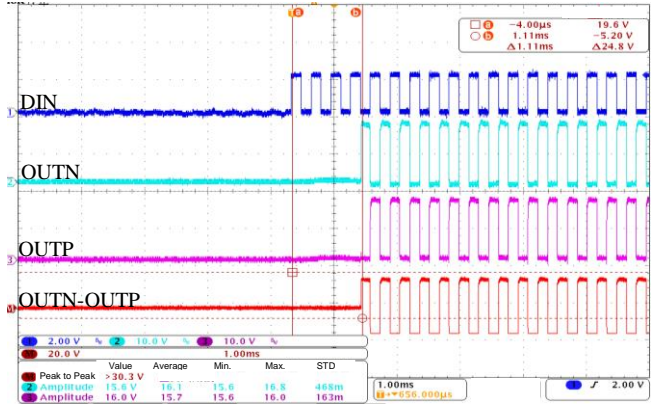

3. Turn-off waveform at $V_{OUT} = 11V$

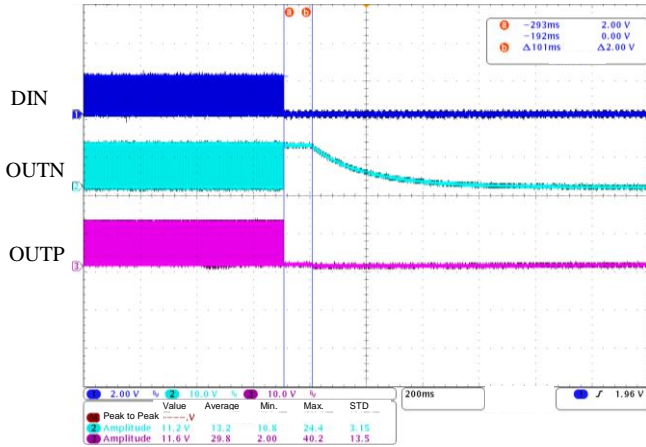

4. Turn-off waveform at $V_{OUT} = 15.6V$

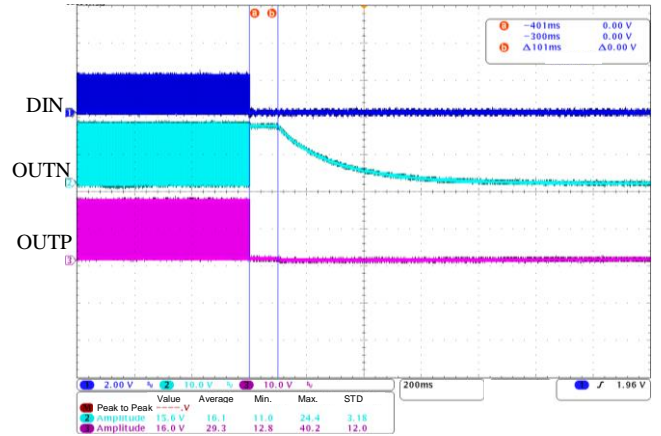

Application Information

Overview:

The PAM8907 is a piezo sounder driver with integrated boost switch, power diodes, and fully differential amplifier. This versatile device is capable of driving piezo sounder for a variety of applications, including location tracker, air humidifier or haptic feedback related applications. The PAM8907 supports selectable boost voltage output by VSET pin for low/high voltage output. A typical start-up time of 1.1ms makes the PAM8907 an ideal piezo driver with fast response. PAM8907 has built-in thermal overload protection, current limit and various protection features to prevent the device from damage when overdriven.

Major functions of PAM8907 along with application information is described in the following sections.

LDO Regulator

The PAM8907 has a built-in 5V LDO regulator to supply 5V to the internal blocks. It is recommended to add 1 μ F capacitor at pin 1 VCC (LDO).

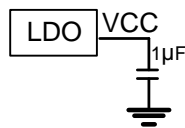

Piezo Driver

As illustrated below, the PAM8907 has a built-in Piezo driver circuitry with Diodes Incorporated's proprietary design. This is to enable easy system configuration for driving piezo sounder with less external components and yet optimized performance.

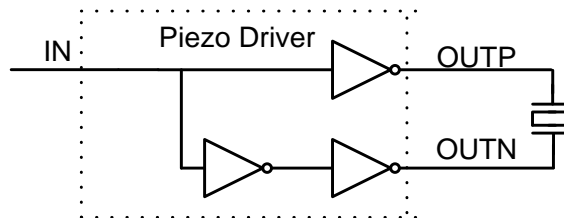

DIN Control

The PAM8907 designs a binary control logic circuit internally for the automatic shutdown and wake-up control, when DIN is set low and continue for longer than 100ms (Typ.) period, PAM8907's boost and Piezo driver block will be disabled and the device automatically enters shutdown mode. The PAM8907's operation current is less than 1 μ A under this shutdown mode. When DIN is set high or provided with pulsed-clock input, PAM8907's boost and Piezo driver block will be enabled again & resumed back to normal operation mode.

Application Information (continued)

Boost Regulator

The PAM8907 boost regulator is a conventional current-mode controller with the following enhanced features:

- **Under Voltage Lock Out (ULVO):** When the input supply (VIN) drops below the UVLO value, the Boost regulator will switch off. Typical UVLO value is 1.6V
- **Over Temperature Protection (OTP):** When PAM8907 die temperature is higher than OTP threshold, the Boost regulator will switch off, and restart after OTP condition is removed. Typical OTP value is set at +160°C.
- **VOUT Under Voltage (UV) Protection:** When the Boost regulator output voltage is lower than the pre-set threshold, it will trigger VOUT UV protection, and the device will go to hiccup mode in order to reduce power supply current.
- **VOUT Over-Voltage (OV) Protection:** When the Boost regulator output voltage is higher than the pre-set threshold, it will trigger VOUT OV protection, and the device will switch off until VOUT OV condition is removed.
- **Soft-Start:** The Boost regulator voltage setting is designed to always operate under soft-start operation, which can reduce in-rush current. Typical soft start time is set around 1.1ms.
- **Over Current Protection (OCP):** The Boost regulator has a built-in cycle-by-cycle over current protection.
- **SLEEP:** The Boost regulator will go to sleep mode under light-load condition.

The PAM8907 has designed the boost regulator as current-mode controller with two control loops, which work together in maintaining a constant output voltage and supply the required load current. The inner current control loop provides cycle-by-cycle current limiting, while the output control loop provides output voltage control. When the boost converter is turned on using the DIN input, the NMOS switch is turned on and the inductor current ramps up to its peak value, approximately 1600mA nominally.

The current comparator turns off the NMOS switch for a fixed period of time to allow energy to be transferred to the output capacitor. When the voltage on the output capacitor equals or exceeds the desired output voltage, the current loop is disabled until the load discharges the output capacitor to a voltage lower than the desired output voltage. Every time the output voltage falls below the desired value, the switching cycle starts and continues until the desired value is reached. The constant switching resulting in the charging and discharging of the output capacitor causes a ripple on the output voltage. The ripple on the output voltage depends on the external component parameters, such as the value of external capacitor, its ESR, and etc.

In PAM8907, when logic high is asserted on the DIN pin, the boost regulator is enabled. However, the Piezo driver output is not enabled until the output voltage reaches its nominal set point (total soft start time around 1.1ms). This ensures the output voltage rises quickly to the necessary drive voltage for the Piezo.

The boost regulator has been optimized to work with the external components as shown in the Typical Application circuit. It is crucial to select an appropriate inductor value for the Boost converter to operate efficiently with expected transient behavior and loop stability under a limited board space condition. 0.68μH to 1.5μH (typical 1.0μH) inductor with saturation current rating of 1A is recommended to optimize PAM8907 performance.

Application Information (continued)

Capacitor Selection Guide

The external capacitors are required to use low ESR ceramic capacitors. It is strongly recommended to place them at the same layout layer as PAM8907.

- **Power Supply Decoupling – VIN (Pin 10)**

Capacitor Value: $1\mu\text{F} + 10\mu\text{F}$

Voltage Rating: $2 \times V_{\text{IN}}$

Capacitor layout: place the $1\mu\text{F}$ capacitor close to VIN (Pin 10), and $10\mu\text{F}$ close to the inductor

- **External LDO – VCC (Pin 1)**

Capacitor Value: $1\mu\text{F}$

Voltage Rating: 10V or 16V

Capacitor layout: place the capacitor close to VCC (Pin 1)

- **Bootstrap – BOOT (Pin 3)**

Capacitor Value: $0.1\mu\text{F}$

Voltage Rating: 25V or higher

Capacitor layout: place the capacitor close to BOOT (Pin 3)

- **Boost Output – VOUT (Pin 5)**

Capacitor Value: $1\mu\text{F}$ or $2.2\mu\text{F}$, for smoke alarm application, if loading is higher than 100nF , put a $10\mu\text{F}$ capacitor at the VOUT pin.

Voltage Rating: 25V or higher

Capacitor layout: place the capacitor close to VOUT (Pin 5)

Schottky Diode

This is optional. A Schottky diode between SW and VOUT (in parallel with high-side FET of the Boost converter) can reduce the power consumption by approximately 20%. A 20V Schottky with current rating of 1A is preferred.

GND Layout Guideline

The GND layout is important to enable PAM8907 to operate under optimal conditions. Suggested layout for GND is illustrated below. Please consult with Diodes Incorporated's technical support team or field representative for any further assistance, if necessary.

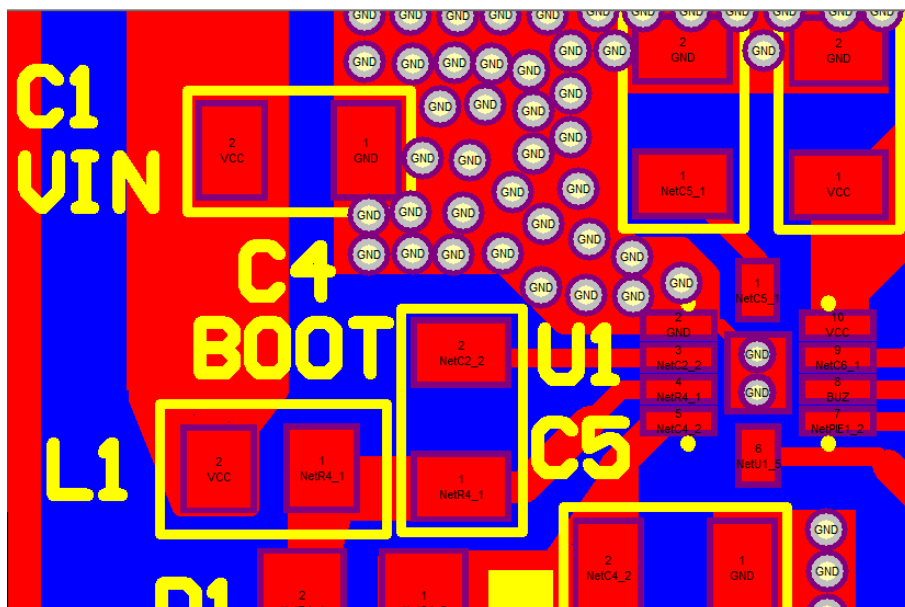

Connect first GND (Pin 2) to PAM8907's epoxy pad, then expand the GND line to VCC/VIN's capacitor's GND and place many vias on the GND trace, then connect with VOUT pin's CAP GND. Place these capacitors as close as possible to PAM8907.

Ordering Information

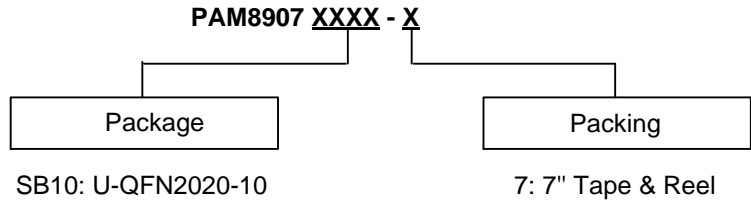

Part Number	Package	Voltage	Quantity	Tape and Reel
PAM8907SB10-7	U-QFN2020-10	11V/15.6V	3,000/Tape & Reel	-7

Marking Information

(Top View)

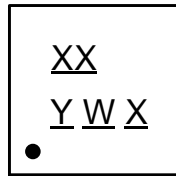

- XX : Identification Code
- Y : Year : 0 to 9
- W : Week : A to Z : 1 to 26 Week;
a to z : 27 to 52 Week; z Represents
52 and 53 Week
- X : Internal Code

Part Number	Package	Identification Code
PAM8907SB10-7	U-QFN2020-10	PJ

Package Outline Dimensions

Please see <http://www.diodes.com/package-outlines.html> for the latest version.

U-QFN2020-10

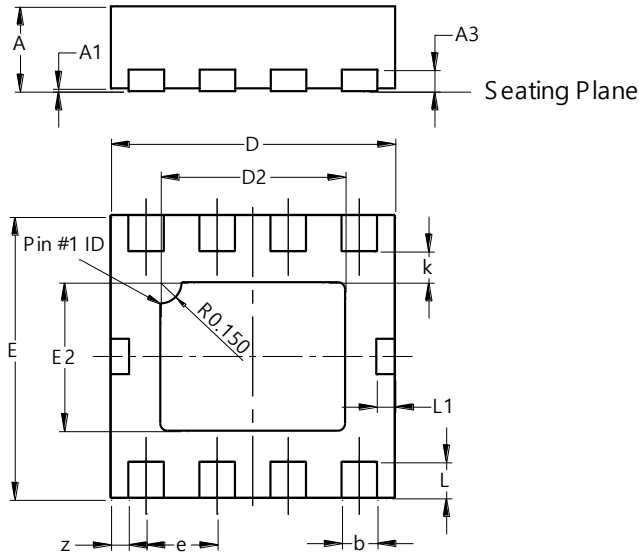

U-QFN2020-10			
Dim	Min	Max	Typ
A	0.57	0.63	0.60
A1	0.00	0.05	0.02
A3	--	--	0.152
b	0.20	0.30	0.25
D	1.950	2.05	2.00
D2	1.20	1.40	1.30
E	1.950	2.05	2.00
E2	0.95	1.15	1.05
e	--	--	0.50
k	--	--	0.23
L	0.205	0.305	0.255
L1	0.100	0.160	0.130
z	--	--	0.125
All Dimensions in mm			

Suggested Pad Layout

Please see <http://www.diodes.com/package-outlines.html> for the latest version.

U-QFN2020-10

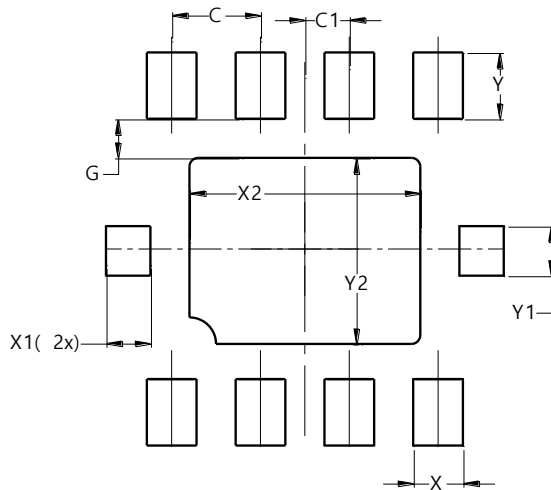

Dimensions	Value (in mm)
C	0.500
C1	0.250
G	0.220
X	0.280
X1	0.250
X2	1.300
Y	0.375
Y1	0.280
Y2	1.050

Mechanical Data

- Moisture Sensitivity: Level 1 per J-STD-020
- Terminals: Finish – NiPdAu, Solderable per J-STD-002, Test B1 (e4)
- Weight: 13.67mg (Approximate)

IMPORTANT NOTICE

1. DIODES INCORPORATED AND ITS SUBSIDIARIES (“DIODES”) MAKE NO WARRANTY OF ANY KIND, EXPRESS OR IMPLIED, WITH REGARDS TO ANY INFORMATION CONTAINED IN THIS DOCUMENT, INCLUDING, BUT NOT LIMITED TO, THE IMPLIED WARRANTIES OF MERCHANTABILITY, FITNESS FOR A PARTICULAR PURPOSE OR NON-INFRINGEMENT OF THIRD PARTY INTELLECTUAL PROPERTY RIGHTS (AND THEIR EQUIVALENTS UNDER THE LAWS OF ANY JURISDICTION).
2. The Information contained herein is for informational purpose only and is provided only to illustrate the operation of Diodes products described herein and application examples. Diodes does not assume any liability arising out of the application or use of this document or any product described herein. This document is intended for skilled and technically trained engineering customers and users who design with Diodes products. Diodes products may be used to facilitate safety-related applications; however, in all instances customers and users are responsible for (a) selecting the appropriate Diodes products for their applications, (b) evaluating the suitability of the Diodes products for their intended applications, (c) ensuring their applications, which incorporate Diodes products, comply the applicable legal and regulatory requirements as well as safety and functional-safety related standards, and (d) ensuring they design with appropriate safeguards (including testing, validation, quality control techniques, redundancy, malfunction prevention, and appropriate treatment for aging degradation) to minimize the risks associated with their applications.
3. Diodes assumes no liability for any application-related information, support, assistance or feedback that may be provided by Diodes from time to time. Any customer or user of this document or products described herein will assume all risks and liabilities associated with such use, and will hold Diodes and all companies whose products are represented herein or on Diodes’ websites, harmless against all damages and liabilities.
4. Products described herein may be covered by one or more United States, international or foreign patents and pending patent applications. Product names and markings noted herein may also be covered by one or more United States, international or foreign trademarks and trademark applications. Diodes does not convey any license under any of its intellectual property rights or the rights of any third parties (including third parties whose products and services may be described in this document or on Diodes’ website) under this document.
5. Diodes products are provided subject to Diodes’ Standard Terms and Conditions of Sale (<https://www.diodes.com/about/company/terms-and-conditions/terms-and-conditions-of-sales/>) or other applicable terms. This document does not alter or expand the applicable warranties provided by Diodes. Diodes does not warrant or accept any liability whatsoever in respect of any products purchased through unauthorized sales channel.
6. Diodes products and technology may not be used for or incorporated into any products or systems whose manufacture, use or sale is prohibited under any applicable laws and regulations. Should customers or users use Diodes products in contravention of any applicable laws or regulations, or for any unintended or unauthorized application, customers and users will (a) be solely responsible for any damages, losses or penalties arising in connection therewith or as a result thereof, and (b) indemnify and hold Diodes and its representatives and agents harmless against any and all claims, damages, expenses, and attorney fees arising out of, directly or indirectly, any claim relating to any noncompliance with the applicable laws and regulations, as well as any unintended or unauthorized application.
7. While efforts have been made to ensure the information contained in this document is accurate, complete and current, it may contain technical inaccuracies, omissions and typographical errors. Diodes does not warrant that information contained in this document is error-free and Diodes is under no obligation to update or otherwise correct this information. Notwithstanding the foregoing, Diodes reserves the right to make modifications, enhancements, improvements, corrections or other changes without further notice to this document and any product described herein. This document is written in English but may be translated into multiple languages for reference. Only the English version of this document is the final and determinative format released by Diodes.
8. Any unauthorized copying, modification, distribution, transmission, display or other use of this document (or any portion hereof) is prohibited. Diodes assumes no responsibility for any losses incurred by the customers or users or any third parties arising from any such unauthorized use.

Copyright © 2021 Diodes Incorporated

www.diodes.com